

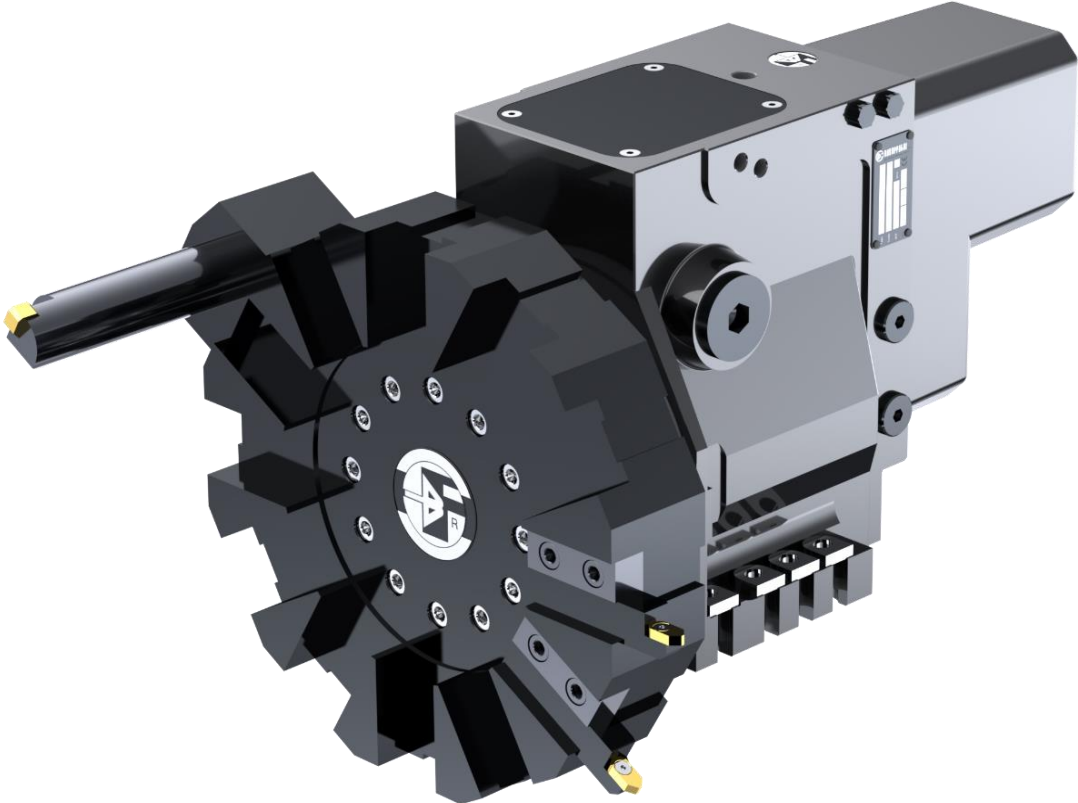

**BARUFFALDI**  
MACHINE TOOL COMPONENTS

The Partner for Machine Tool  
Builders

TE Electromechanical Turrets **guide**  
Catalogo torrette elettromeccaniche TE



[WWW.BARUFFALDI.IT](http://WWW.BARUFFALDI.IT)



Rev. 2019



1927



Eng. Cesare Boffelli

Baruffaldi was founded in Milano (Italy) by Cesare Boffelli, a qualified mechanical engineer, in 1927

1932



Motorcycle Certum from '30s

The Company started the production of brakes for motorcycles in the '30s

1955



Baruffaldi Catalog

In the '50s Baruffaldi expanded its business area manufacturing brakes and clutches for several industrial applications

1972



Fiat Truck '70s

With high technology knowledge in brake and clutches The Company became a partner of truck manufacturers

# BARUFFALDI

In the '70s it began the production of components for Machine Tool industry

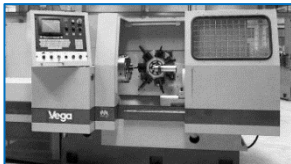

PPL "Galaxy" turning lathe '70s

1975

Baruffaldi entered the agricultural and textile machines industries



Agricultural Tractor '80s

1984

Baruffaldi reorganized the company into 2 new production units located in Milan area. The total covered area is 25.000sqm



Baruffaldi Production Units

2007

Today Baruffaldi, with over 90 years of experience, is one of the leaders in the Machine Tool Industry offering high quality products and services worldwide.

Oggi Baruffaldi, con oltre 90 anni di esperienza, è una dei leader del settore delle Macchine Utensili offrendo prodotti di alta qualità e servizi in tutto il mondo.

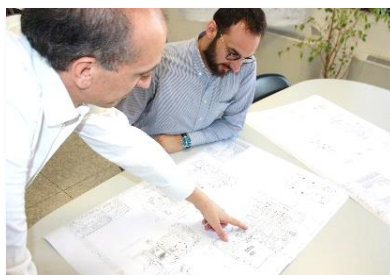

**Baruffaldi, The Partner for Machine Tool Builders**

## TE Electromechanical Turrets - Introduction

### TE Torrette Elettromeccaniche - Introduzione

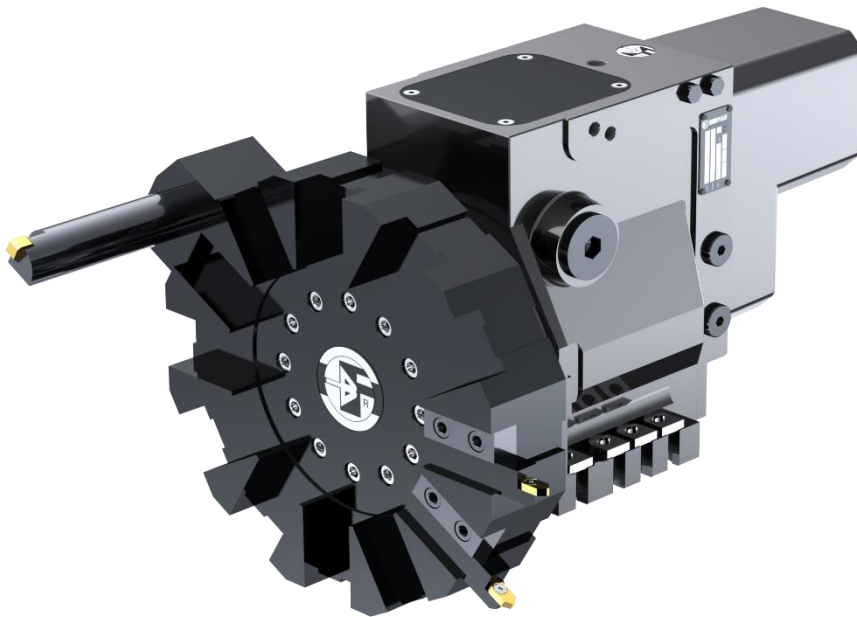

The TE turrets, horizontal vertical axis units, are fully electromechanical. A single AC Motor drives the unlocking movement, rotation, positioning and locking movement.

They do not require any additional hydraulic or pneumatic connection and/or component.

An electromagnetic brake (24V supply), as part of the motor, holds the turret in position and prevents the turret from unlocking due to vibrations.

#### **Main Characteristics:**

- Full electromechanical
- Low indexing time
- Bi-Directional disc rotation
- High rigidity
- Wide range: TE120,160, 200, 250
- Possibility to use 4-6-8-12 positions discs
- Many different configurations and special applications available

Le torrette TE, unità ad asse orizzontale, sono completamente elettromeccaniche, un singolo motore AC sblocca l'unità, esegue la rotazione disco, il posizionamento e il bloccaggio della torretta.

Non è richiesto l'utilizzo e la connessione ad alcuna unità idraulica/pneumatica o altri componenti aggiuntivi.

Un freno elettromagnetico (24V), montato all'interno del motore, tiene la torretta in posizione evitando uno sbloccaggio imprevisto a causa vibrazioni.

#### **Caratteristiche principali:**

- Completamente elettromeccanica
- Minimi tempi di posizionamento
- Rotazione bi-direzionale
- Alta rigidità
- Ampia gamma di taglie: TE120,160, 200, 250
- Possibilità di utilizzo dischi a 4-6-8-12 posizioni
- Tante differenti configurazioni e applicazioni speciali sono disponibili

## TE Turrets - General technical data

### Torrette TE - Dati tecnici generali

Size <i>Taglia</i>			TE 120	TE 160	TE 200	TE 250
Number of division <i>Numero di posizioni</i>			4 - 6 - 8 - 12			
Direction of rotation <i>Direzione di rotazione</i>			Bidirectional <i>Bidirezionale</i>			
Moment of Inertia <i>Momento d'inerzia</i>	Kgm <sup>2</sup>		1,2		6	
Max tangential torque <i>Max coppia tangenziale</i>	Nm		1100	1900	4000	7500
Max Overturning torque (pressing) <i>Max coppia ribaltante (a premere)</i>			1200	2100	6000	12000
Max Overturning torque (lifting) <i>Max coppia ribaltante (a sollevare)</i>			700	1600	3500	6500
Max Unbalancing torque <i>Max coppia sbilanciata</i>			10	15	40	60
Positioning accuracy <i>Precisione di posizionamento</i>	Deg.		±4"			
Accuracy of repeatability <i>Accuratezza Ripetibilità</i>			±1,6"			
Positining time * <i>Tempo di Posizionamento *</i>	30°	sec	0,36		0,45	
	45°	sec	0,45		0,57	
	180°	sec	1,25		1,7	
Unlocking + Locking time <i>Tempo di sbloccaggio + bloccaggio</i>	sec		0.5		0.9	
Indexing frequency* <i>Frequenza cambio utensile*</i>	n°/h		800	700	550	400
Motor voltage <i>Voltaggio motore</i>	V		110 – 220 - 380			
Max coolant pressure (standard version) <i>Max Pressione refrigerante (versione standard)</i>	bar		20			
Max coolant pressure (special version) <i>Max Pressione refrigerante (versione speciale)</i>	bar		70			
Ambient temperature range <i>Temperatura ambiente</i>	°C		0-40			
Protection degree <i>Gradi di protezione</i>	IP		65			

\*This value could change according to the characteristic of the environment, tool holder disc type and weight of the tool holders

\*I tempi possono variare a seconda delle caratteristiche dell'ambiente, del disco portautensile e del peso dei porta utensili

## TE Turrets - Loading capacity

### Torrette TE - Capacità di carico

Following diagrams refer to forced applied to tool holder disc. For loading capacity of static tool holders please refer to manufacturer's data sheet.

Il diagramma seguente si riferisce alle forze applicabili al disco portautensile. Per la capacità dei portautensili consultare i dati forniti dai rispettivi produttori.

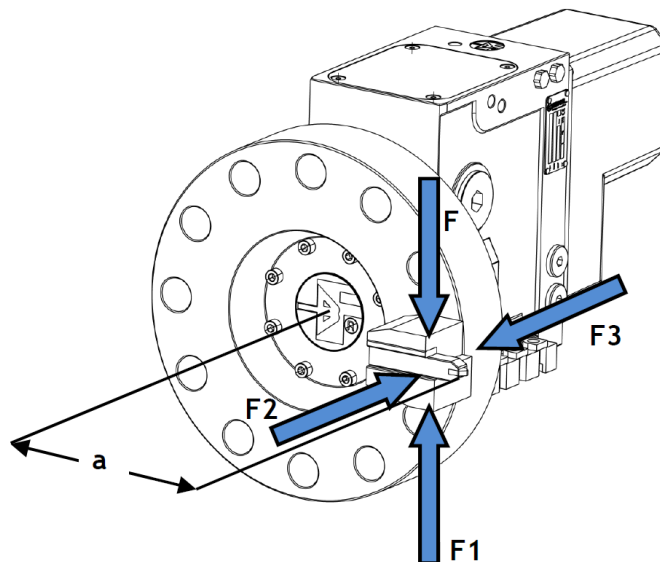

F-F1 Tangential / Tangenziale

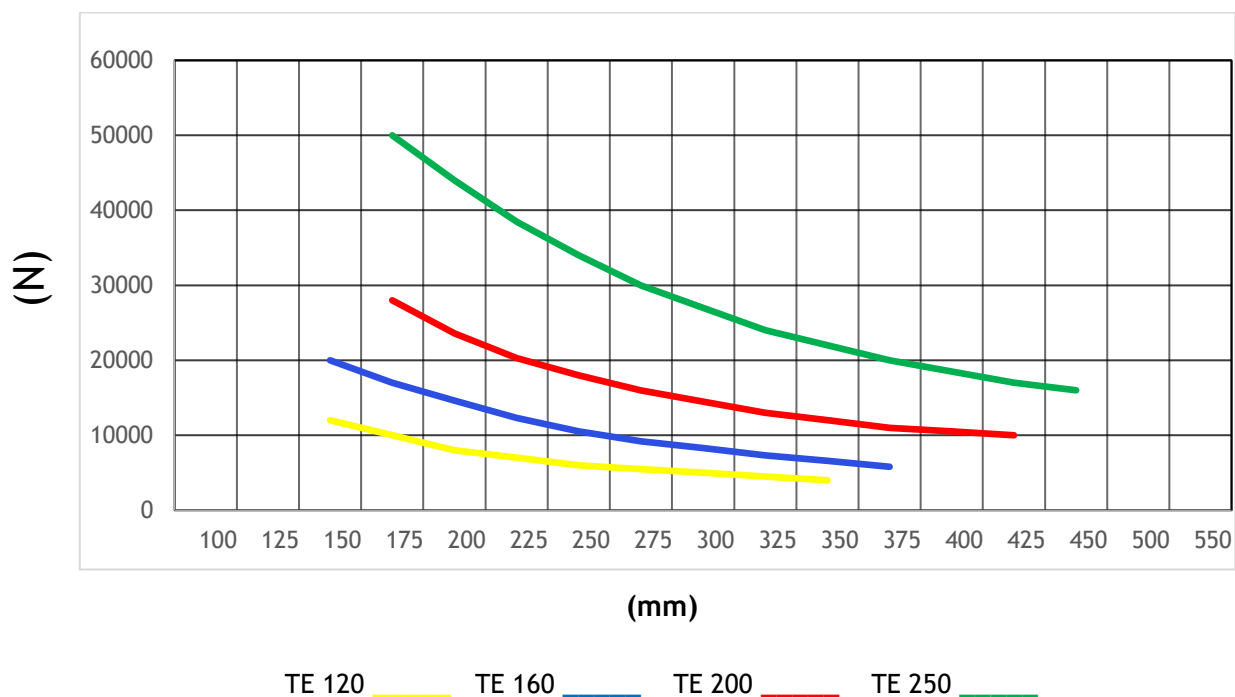

### F2 To Push / A Premere

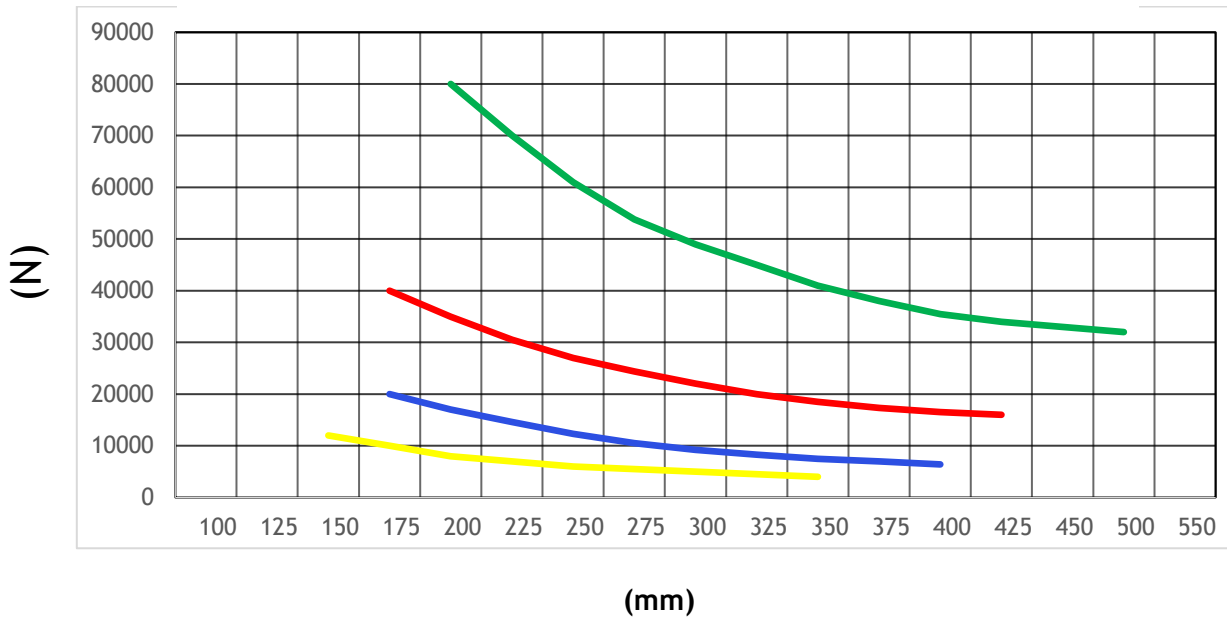

TE 120 — TE 160 — TE 200 — TE 250 —

### F3 To Lift / A Sollevare

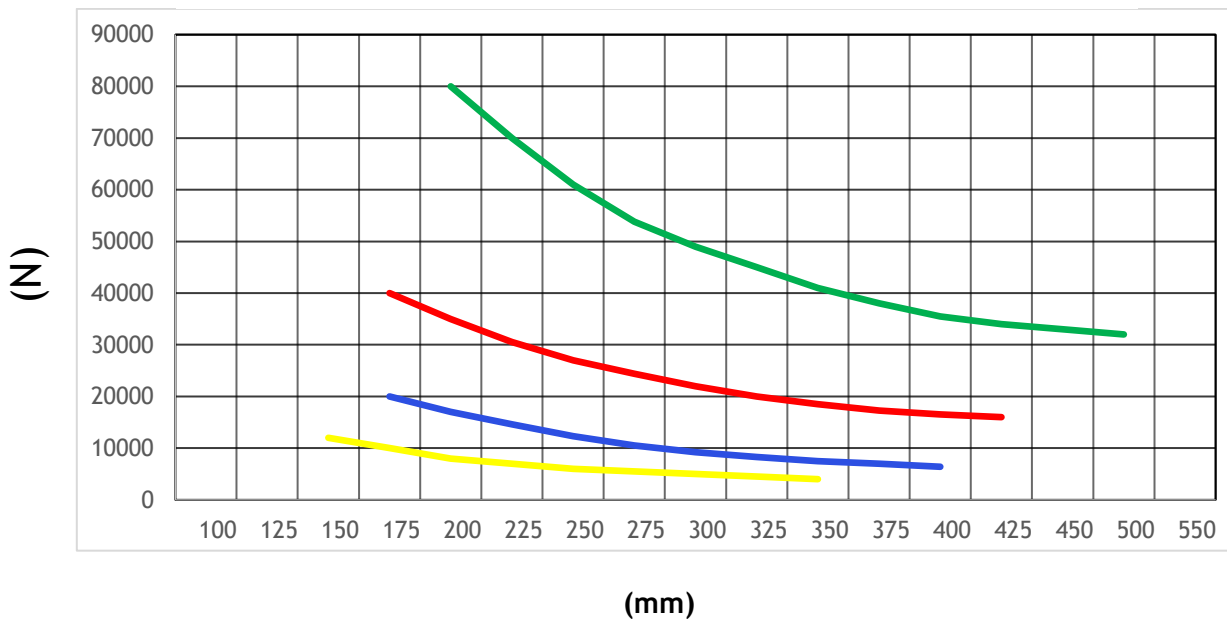

TE 120 — TE 160 — TE 200 — TE 250 —

# TE Turrets - Order Code

## Torrette TE - Codice per l'ordinazione

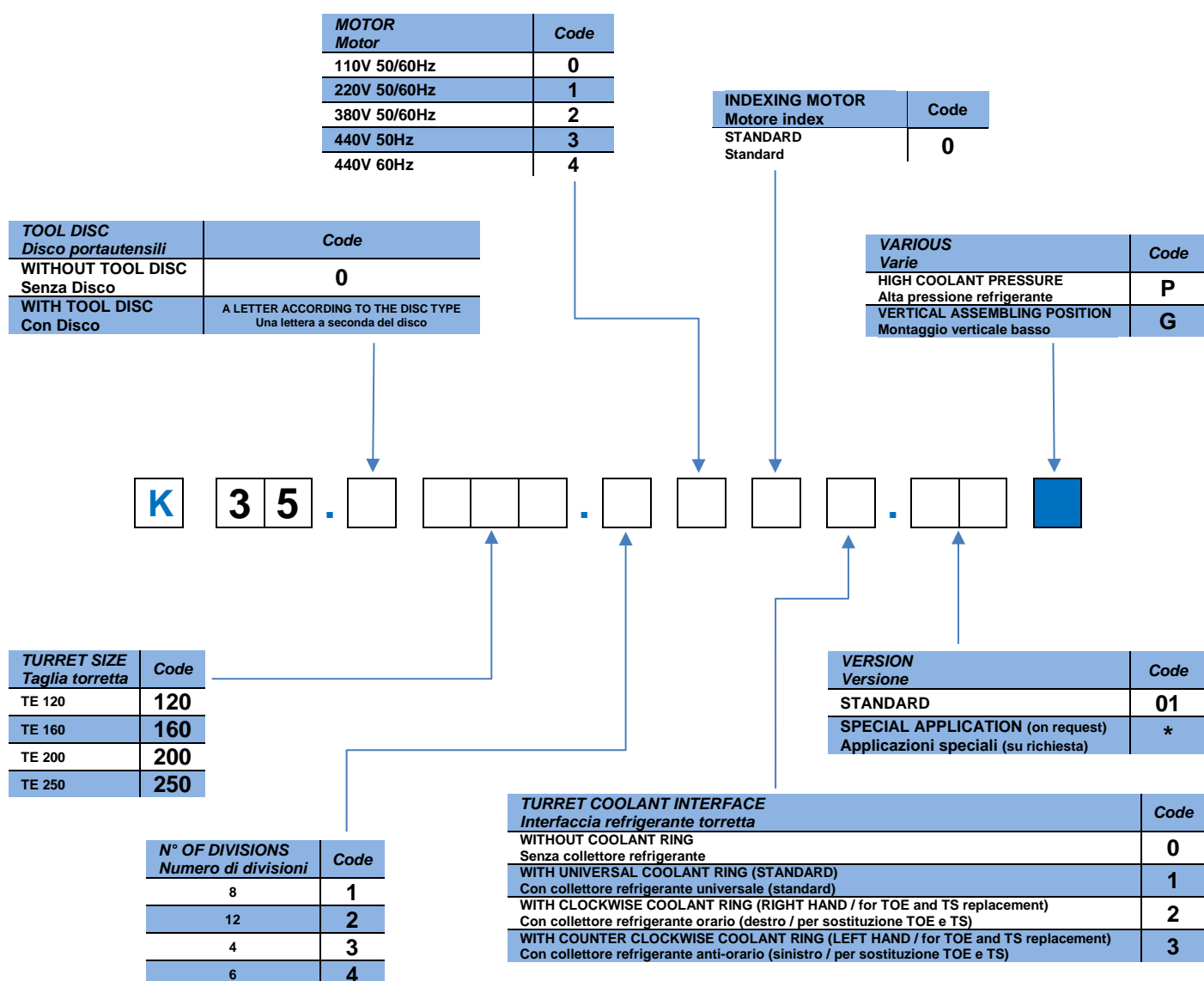



### Torrette TE - Dischi portautensili

The Turrets TE could be equipped with several Tool Discs type:

Le torrette TE possono essere fornite con svariati tipi di Dischi Portautensili:

**VDI Axial Discs (Standard)**  
Disco Assiale VDI (Standard)



**Polygonal Slotted Discs**  
Disco poligonale a sedi fresate



**VDI Radial Discs**  
Disco Radiale VDI



**BMT Radial Discs**  
Disco Radiale BMT



**VDI Axial Discs with double PCD**  
Disco VDI assiale doppio interasse



**Capto Discs (Radial or Axial)**  
Disco con sedi Capto (Radiali o Assiali)



**VDI Axial Discs + Side Slots**  
Disco Assiale VDI + sedi fresate laterali



**VDI Axial Discs + Frontal and Side Slots**  
Disco Assiale VDI + sedi fresate



Other Tool Discs or other solutions are available on request, please contact our sales office ([sales.mtc@baruffaldi.it](mailto:sales.mtc@baruffaldi.it)) or check our Tool Disc Catalog.

Altri Dischi o altre soluzioni sono disponibili a richiesta, contattare il nostro ufficio commerciale ([sales.mtc@baruffaldi.it](mailto:sales.mtc@baruffaldi.it)) o consultare il catalogo dei Dischi Portautensili.



## TE Turrets - Turret function description

### Torrette TE - Descrizione di funzionamento torretta

These turrets are fully electromechanical; one single AC motor drives the unlocking movement, rotation, positioning and locking movement.

They do not require any additional hydraulic or pneumatic connection and/or component.

An electromagnetic brake (24V supply), as part of the motor, holds the turret in position and prevents the turret from unlocking due to vibrations.

*Queste torrette sono completamente elettromeccaniche, un singolo motore AC sblocca l'unità, esegue la rotazione disco, il posizionamento e il bloccaggio della torretta.*

*Non è richiesto l'utilizzo e la connessione con alcuna unità idraulica/pneumatica o altri componenti aggiuntivi.*

*Un freno elettromagnetico (24V), montato all'interno del motore, tiene la torretta in posizione evitando uno sbloccaggio imprevisto a causa vibrazioni.*

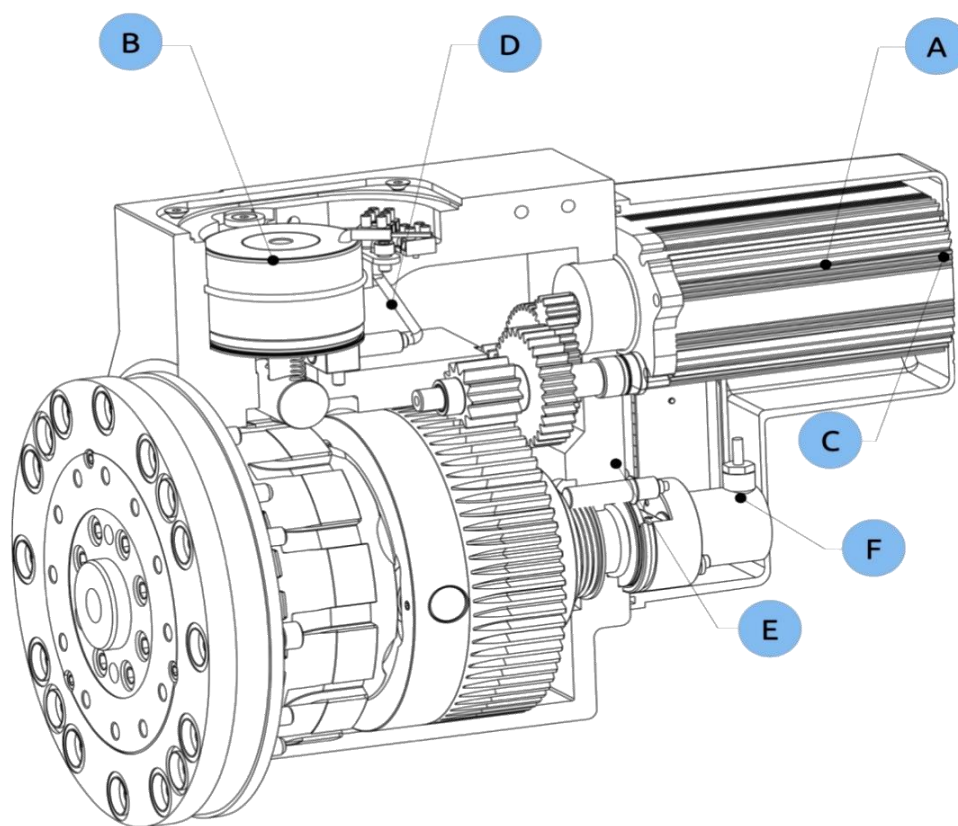

- A** Three-phase asynchronous motor
- B** Electromagnet
- C** Motor brake
- D** Pre-index proximity switch
- E** Locking proximity switch
- F** Angular position – absolute encoder

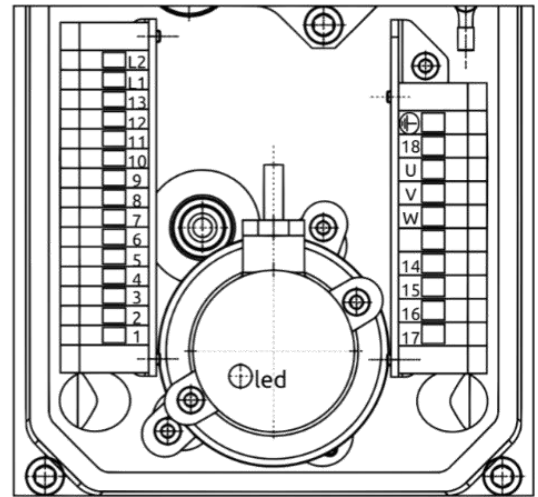
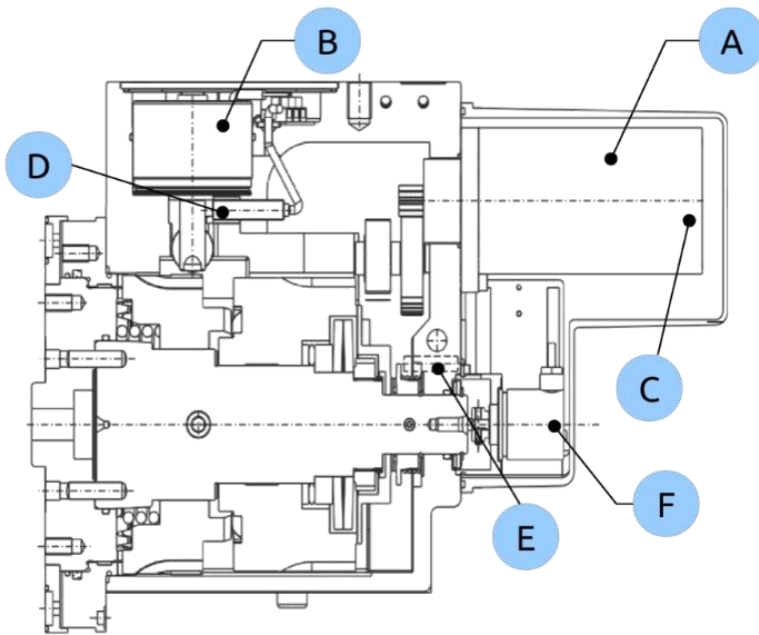

A	<b>Motor With thermal detector</b>	220/380V 50/60Hz 1KVA  PTC N.C. Open@120 °C		<table border="1"> <tr><td>U</td><td>Red</td><td></td></tr> <tr><td>V</td><td>Red</td><td></td></tr> <tr><td>W</td><td>Red</td><td></td></tr> <tr><td>18</td><td>Black</td><td>X</td></tr> <tr><td>18</td><td>Black</td><td>Y</td></tr> <tr><td>18</td><td>Black</td><td>Z</td></tr> <tr><td>14</td><td>White</td><td>Thermic</td></tr> <tr><td>15</td><td>White</td><td>Thermic</td></tr> </table>	U	Red		V	Red		W	Red		18	Black	X	18	Black	Y	18	Black	Z	14	White	Thermic	15	White	Thermic	<table border="1"> <thead> <tr> <th colspan="2">Wiring Y 380V</th> <th colspan="2">Wiring Δ 220V</th> </tr> </thead> <tbody> <tr><td>U</td><td>●</td><td>U</td><td>●</td></tr> <tr><td>V</td><td>●</td><td>V</td><td>●</td></tr> <tr><td>W</td><td>●</td><td>W</td><td>●</td></tr> <tr><td>X</td><td>●</td><td>X</td><td>●</td></tr> <tr><td>Y</td><td>●</td><td>Y</td><td>●</td></tr> <tr><td>Z</td><td>●</td><td>Z</td><td>●</td></tr> </tbody> </table>	Wiring Y 380V		Wiring Δ 220V		U	●	U	●	V	●	V	●	W	●	W	●	X	●	X	●	Y	●	Y	●	Z	●	Z	●																																																											
U	Red																																																																																																																			
V	Red																																																																																																																			
W	Red																																																																																																																			
18	Black	X																																																																																																																		
18	Black	Y																																																																																																																		
18	Black	Z																																																																																																																		
14	White	Thermic																																																																																																																		
15	White	Thermic																																																																																																																		
Wiring Y 380V		Wiring Δ 220V																																																																																																																		
U	●	U	●																																																																																																																	
V	●	V	●																																																																																																																	
W	●	W	●																																																																																																																	
X	●	X	●																																																																																																																	
Y	●	Y	●																																																																																																																	
Z	●	Z	●																																																																																																																	
B	<b>Electromagnet</b>	24Vdc 65W		<table border="1"> <tr><td>12</td><td>Orange</td><td></td></tr> <tr><td>13</td><td>Orange</td><td></td></tr> </table>	12	Orange		13	Orange																																																																																																											
12	Orange																																																																																																																			
13	Orange																																																																																																																			
C	<b>Motor Brake</b>	24Vdc 18W		<table border="1"> <tr><td>16</td><td>Black</td><td></td></tr> <tr><td>17</td><td>Black</td><td></td></tr> </table>	16	Black		17	Black																																																																																																											
16	Black																																																																																																																			
17	Black																																																																																																																			
D	<b>Pre-index proximity switch</b>	24Vdc NO-PNP Load max 200mA		<table border="1"> <tr><td>7</td><td>Brown</td><td>+24Vdc</td></tr> <tr><td>8</td><td>Blue</td><td>0Vdc</td></tr> <tr><td>10</td><td>Black</td><td>Output</td></tr> </table>	7	Brown	+24Vdc	8	Blue	0Vdc	10	Black	Output	Protected against short circuit and polarity reverse																																																																																																						
7	Brown	+24Vdc																																																																																																																		
8	Blue	0Vdc																																																																																																																		
10	Black	Output																																																																																																																		
E	<b>Locking proximity switch</b>	24Vdc NO-PNP Load max 200mA		<table border="1"> <tr><td>7</td><td>Brown</td><td>+24Vdc</td></tr> <tr><td>8</td><td>Blue</td><td>0Vdc</td></tr> <tr><td>11</td><td>Black</td><td>Output</td></tr> </table>	7	Brown	+24Vdc	8	Blue	0Vdc	11	Black	Output	Protected against short circuit and polarity reverse																																																																																																						
7	Brown	+24Vdc																																																																																																																		
8	Blue	0Vdc																																																																																																																		
11	Black	Output																																																																																																																		
F	<b>Angular position Absolute Encoder 8/12 pos</b>	24Vdc ±10% 40mA(max exit load)  PNP open collector  Protected against short circuit	<p>*Against noises interference use shielded cable</p>	<table border="1"> <tr><td>1</td><td>White</td><td>Bit_1</td></tr> <tr><td>2</td><td>Yellow</td><td>Bit_2</td></tr> <tr><td>3</td><td>Green</td><td>Bit_3</td></tr> <tr><td>4</td><td>Violet</td><td>Bit_4</td></tr> <tr><td>5</td><td>Red</td><td>Parity</td></tr> <tr><td>6</td><td>Black</td><td>Strobe</td></tr> <tr><td>7</td><td>Brown</td><td>+24Vdc</td></tr> <tr><td>8</td><td>Blue</td><td>0 Vdc</td></tr> <tr><td>9</td><td>Diff.size</td><td>Shield</td></tr> </table>	1	White	Bit_1	2	Yellow	Bit_2	3	Green	Bit_3	4	Violet	Bit_4	5	Red	Parity	6	Black	Strobe	7	Brown	+24Vdc	8	Blue	0 Vdc	9	Diff.size	Shield	<table border="1"> <thead> <tr><th colspan="12">Positions</th></tr> <tr><th>1</th><th>2</th><th>3</th><th>4</th><th>5</th><th>6</th><th>7</th><th>8</th><th>9</th><th>10</th><th>11</th><th>12</th></tr> </thead> <tbody> <tr><td>1</td><td>0</td><td>1</td><td>0</td><td>1</td><td>0</td><td>1</td><td>0</td><td>1</td><td>0</td><td>1</td><td>0</td></tr> <tr><td>0</td><td>1</td><td>1</td><td>0</td><td>0</td><td>1</td><td>1</td><td>0</td><td>0</td><td>1</td><td>1</td><td>0</td></tr> <tr><td>0</td><td>0</td><td>0</td><td>1</td><td>1</td><td>1</td><td>1</td><td>0</td><td>0</td><td>0</td><td>0</td><td>1</td></tr> <tr><td>0</td><td>0</td><td>0</td><td>0</td><td>0</td><td>0</td><td>0</td><td>1</td><td>1</td><td>1</td><td>1</td><td>1</td></tr> <tr><td>1</td><td>1</td><td>0</td><td>1</td><td>0</td><td>0</td><td>1</td><td>1</td><td>0</td><td>0</td><td>1</td><td>0</td></tr> </tbody> </table> <p>The led on the back is on with turret in position 1 + strobe</p>	Positions												1	2	3	4	5	6	7	8	9	10	11	12	1	0	1	0	1	0	1	0	1	0	1	0	0	1	1	0	0	1	1	0	0	1	1	0	0	0	0	1	1	1	1	0	0	0	0	1	0	0	0	0	0	0	0	1	1	1	1	1	1	1	0	1	0	0	1	1	0	0	1	0
1	White	Bit_1																																																																																																																		
2	Yellow	Bit_2																																																																																																																		
3	Green	Bit_3																																																																																																																		
4	Violet	Bit_4																																																																																																																		
5	Red	Parity																																																																																																																		
6	Black	Strobe																																																																																																																		
7	Brown	+24Vdc																																																																																																																		
8	Blue	0 Vdc																																																																																																																		
9	Diff.size	Shield																																																																																																																		
Positions																																																																																																																				
1	2	3	4	5	6	7	8	9	10	11	12																																																																																																									
1	0	1	0	1	0	1	0	1	0	1	0																																																																																																									
0	1	1	0	0	1	1	0	0	1	1	0																																																																																																									
0	0	0	1	1	1	1	0	0	0	0	1																																																																																																									
0	0	0	0	0	0	0	1	1	1	1	1																																																																																																									
1	1	0	1	0	0	1	1	0	0	1	0																																																																																																									

# TE Turrets - Electrical connection and Duty Cycle

## Torrette TE- Conessioni elettriche e Ciclogramma

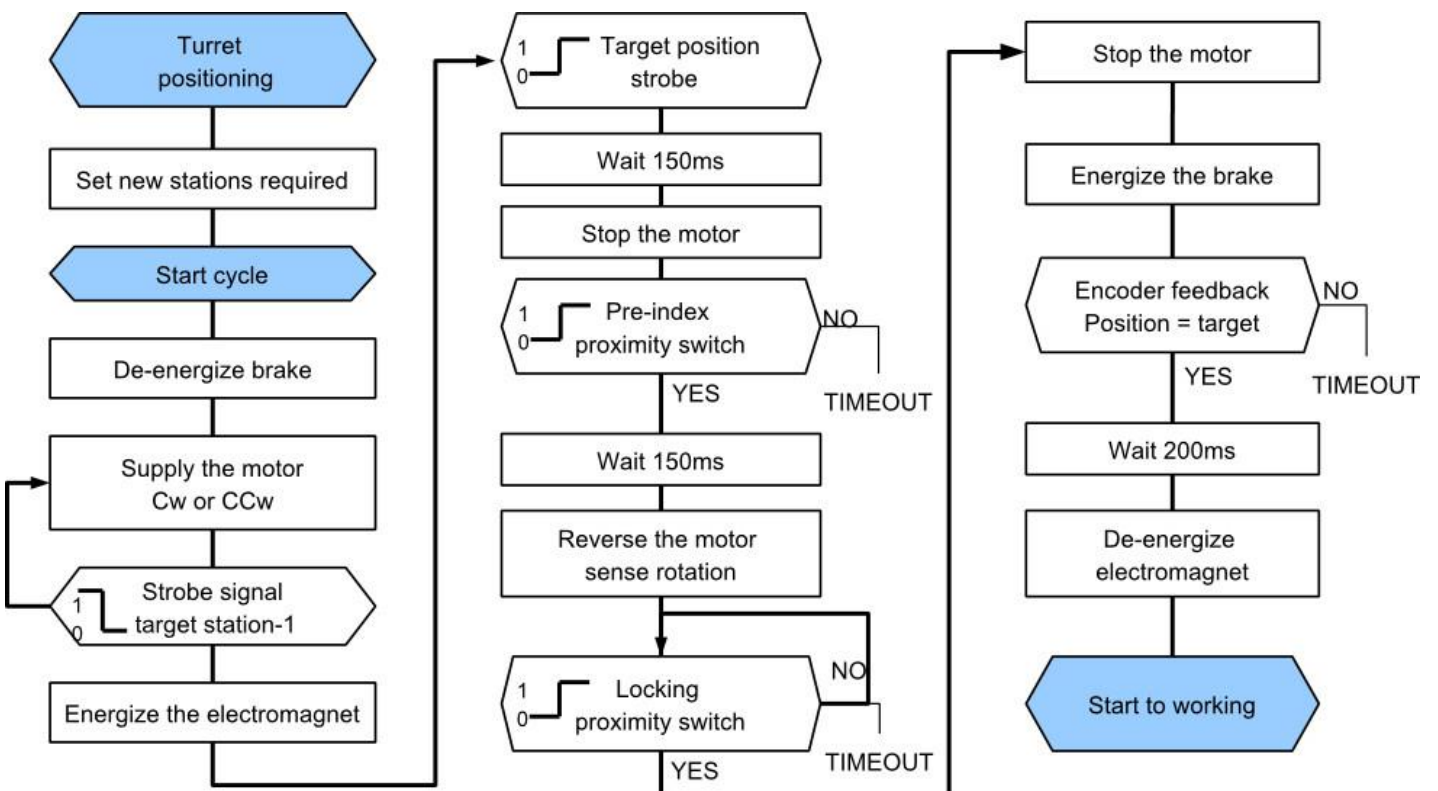
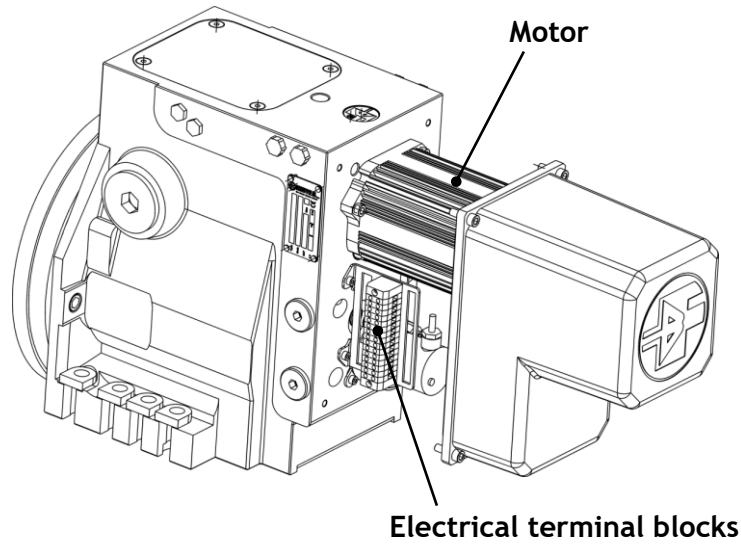

## TE Turrets - Coolant pressure and connections

### Torrette TE- Connessioni e pressione refrigerante

The standard TE can be used with a coolant pressure through the disc up to 40bar.

La TE standard può essere utilizzata con passaggio refrigerante attraverso il disco fino a 40bar.

Baruffaldi has developed a special solution that allows to reach 70bar with coolant.

Baruffaldi ha sviluppato una speciale soluzione che permette di raggiungere i 70bar.

TURRET TYPE <i>Tipo Torretta</i>	TURRET SIZE <i>Taglia Torretta</i>	HOLE <i>Foro</i>	CONNECTION <i>Connessione</i>	OUTPUT <i>Uscita</i>	PRESSURE <i>Pressione</i>	PRESSURE (option) <i>Pressione (opzionale)</i>
TE	120	G 1/4"	C1-C2	E1-E2	40 bar	70 bar
TE	160-200	G 3/8"	C1-C2	E1-E2	40 bar	70 bar
TE	250	G 1/2"	C1-C2	E1-E2	40 bar	70 bar

#### STANDARD COOLANT and 70bar COOLANT

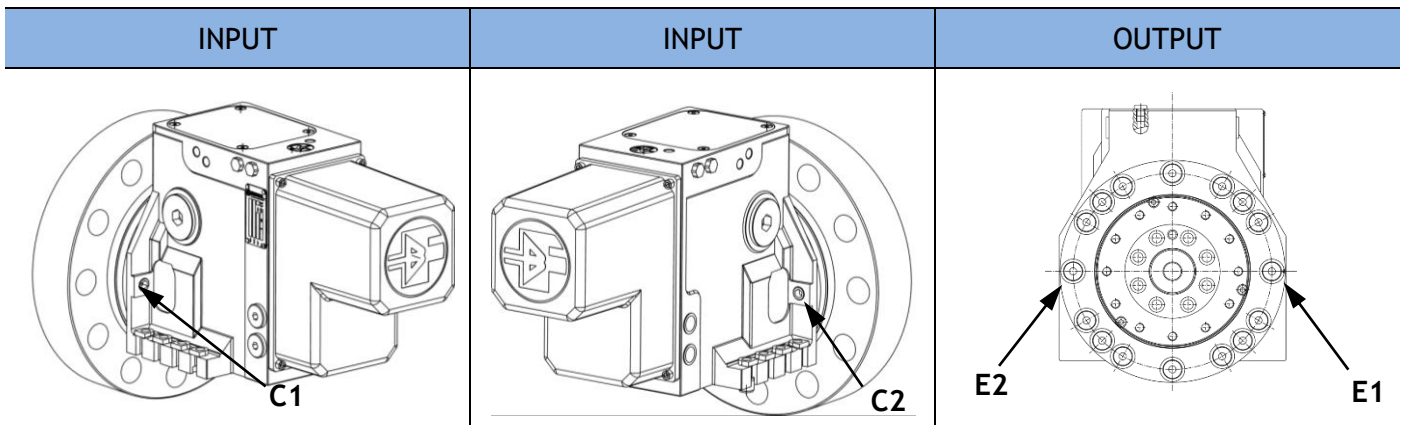







# TE2000 Drawing

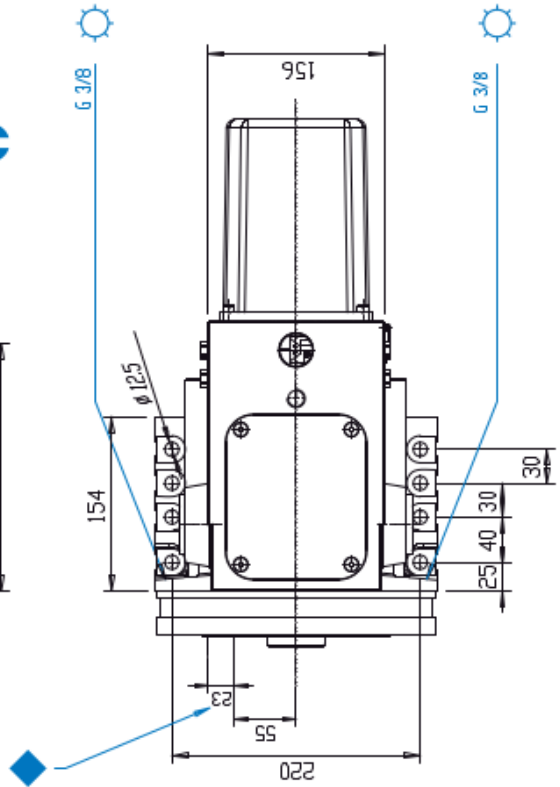
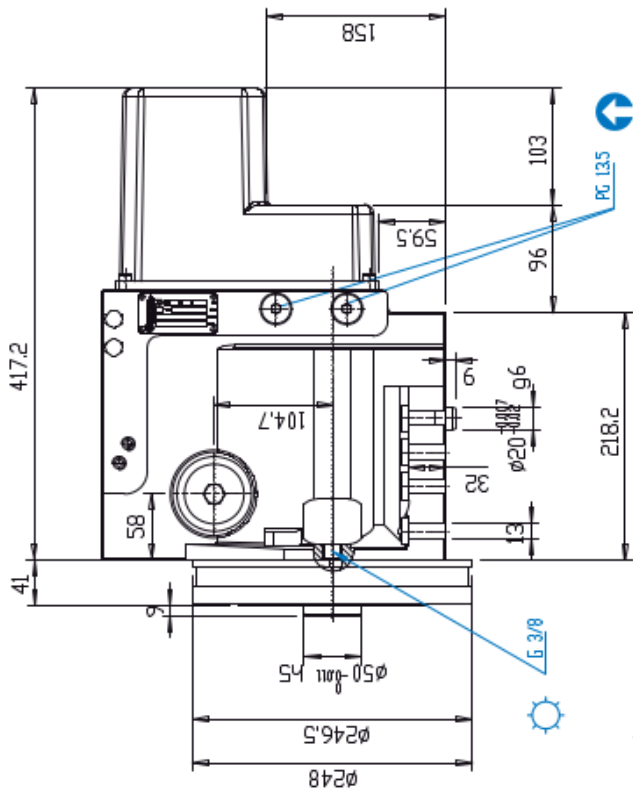
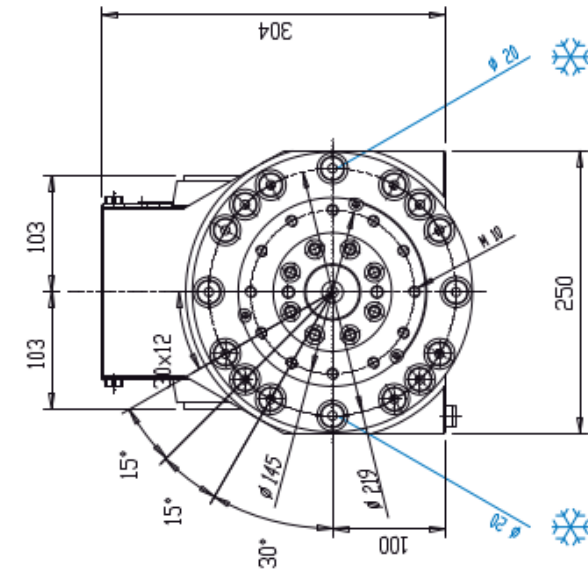





## Worldwide sales and service organization

### Organizzazione mondiale di vendite e servizi



Baruffaldi has developed a sales and service organisation all over the world.

Furthermore, thanks to a net of agents and distributors, it is ensured a direct contact in many nations.

La Baruffaldi è strutturata per offrire un servizio di vendita e assistenza in tutto il mondo.

Inoltre grazie ad una rete di agenti e distributori garantisce un contatto diretto in molte nazioni.

**Visit our web site for more information  
[WWW.BARUFFALDI.IT](http://WWW.BARUFFALDI.IT)**



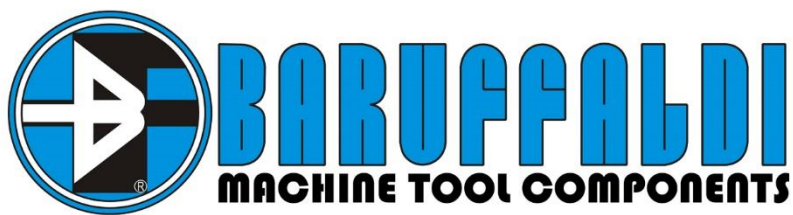

Via Cassino D'Alberi 16, 20067 Tribiano (Milan) ITALY  
Tel +39 02906090 Fax +39 02906090 915  
Email Sales.mtc@baruffaldi.it  
P.Iva / Vat 00757870159



[www.Baruffaldi.it](http://www.Baruffaldi.it)



[facebook.com/BaruffaldiSpa](https://facebook.com/BaruffaldiSpa)



[twitter.com/BaruffaldiSpa](https://twitter.com/BaruffaldiSpa)



[youtube.com/BaruffaldiSpa](https://youtube.com/BaruffaldiSpa)