



BARUFFALDI
MACHINE TOOL COMPONENTS

High precision mechanical
industries development

Frontal teeth rings **guide**

Catalogo anelli dentati

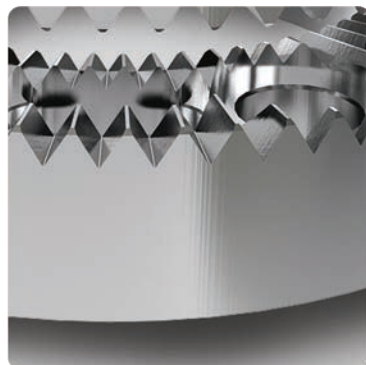
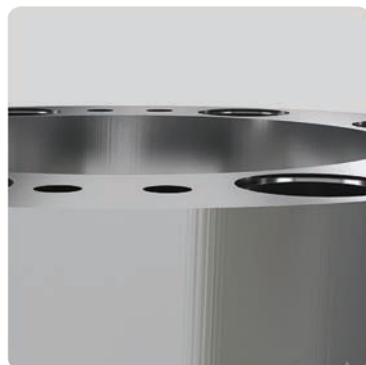

ISSUED 10/2011

www.baruffaldi.it



Baruffaldi S.p.a.

High precision mechanical industries development

Baruffaldi has been in the mechanical branch since 30s producing brakes for motorcycles.

Thanks to the development of the market and to the experience gained, during the 70s, Baruffaldi started the production of components for machine tools, gearboxes, and electromechanical turrets for CNC lathes.

Attentive to the needs and demands of new technology, Baruffaldi has been able to develop the precise and safe product requested by the machine tools market, with particular attention to the new servomotor turrets, to the 2 speed gearboxes, the toolholder discs, the driven tools and the new B axis and Y axis devices.

These products successfully met the market demands, which permitted Baruffaldi to be soon a leading company in the mechanical industry.

Nowadays, the products have maintained their high quality standard, but their technical characteristics have been considerably improved thanks to a continuous cooperation among the design, test, production, and sales departments.

Baruffaldi is now developing its business in the two NEW branches of Settala (Machine Tools Components) and Tribiano (Electromagnetic Clutches and Brakes), on an area of 23.000 covered square meters.

Baruffaldi sells its product line and provides service all over the world thanks to sales managers and technical services operating in the most industrialized Countries.

Baruffaldi ha iniziato la propria attività nella meccanica negli anni 30, producendo freni per motociclette.

Grazie allo sviluppo del mercato e all'esperienza conseguita, durante gli anni 70, la Baruffaldi ha avviato la produzione di componenti per macchine utensili, cambi a due velocità e torrette elettromeccaniche per torni CNC.

Attenta alle necessità e alle domande di nuova tecnologia, la Baruffaldi è stata capace di sviluppare un prodotto preciso e sicuro come richiesto dal mercato di macchine utensili, prestando particolare attenzione alle nuove torrette con servomotore, cambi a due velocità, dischi portautensili, moduli rotanti, torrette e i nuovi asse-B e asse-Y.

Questi prodotti hanno soddisfatto con successo le domande di mercato, consentendo alla Baruffaldi di essere presto leader tra i produttori nell'industria meccanica.

Oggi giorno, i prodotti hanno mantenuto il loro alto livello di qualità ma sono state migliorate notevolmente le loro caratteristiche tecniche grazie a una cooperazione continua tra la progettazione, la produzione, i test e gli uffici vendite.

La Baruffaldi, ora, sta sviluppando la sua attività su un'area di 23.000 metri quadrati coperti, nei due nuovi stabilimenti di Settala (componenti per macchine utensili) e di Tribiano (frizioni e freni elettromagnetici).

La Baruffaldi, grazie a direttori commerciali e servizio tecnico operativi nella maggior parte dei paesi industrializzati, vende la sua linea di prodotti e fornisce assistenza in tutto il mondo.





Thoothed 3-ring sets (custom design)

Set di 3 anelli dentati (su disegni cliente)

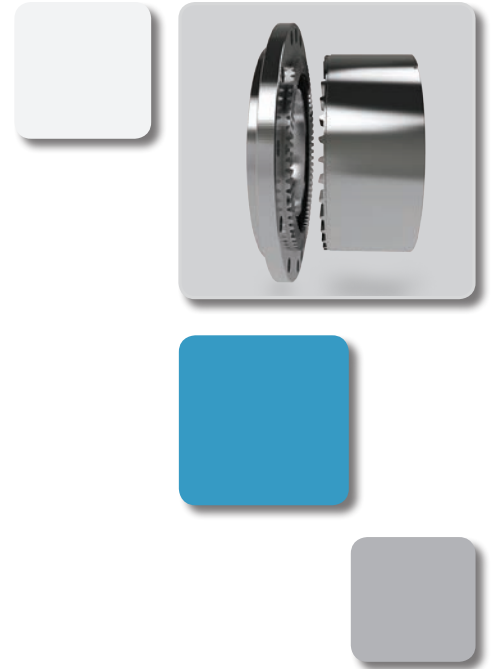

In all indexing systems, such as turning tables, revolver turrets, B-Axis units, turn-mill electrospondles and so on, frontal teeth rings are used, in order to achieve high division precision and repeatability, together with extremely high stiffness and load capacities.

Baruffaldi has been manufacturing frontal teeth rings for over 40 years, ever since revolver turrets production started in the seventies.

Thanks to its long manufacturing experience and design optimization, Baruffaldi offers custom frontal teeth 3-ring units for all devices, designed and produced according to customer specifications and drawings.

Main features

- 3-ring frontal teeth system, no lifting of indexing components
- High precision and positioning repeatability
- Different number of teeth in order to meet customer's division demands
- 20 deg teeth taper, which ensures high rigidity and high loading capacities
- Fully customized, they can replace any 3-ring indexing system previously used

In tutti i sistemi di indexaggio, come tavole rotanti, torrette cambio utensili, Assi B, elettromandri per tornio-fresa ecc, vengono utilizzati sistemi a dentatura frontale, per ottenere elevate precisioni di divisione e di ripetibilità unite ad elevatissima rigidità e capacità di carico.

Baruffaldi produce anelli a dentatura frontale da oltre 40 anni, da quando è iniziata la produzione di torrette cambio utensili negli anni 70.

Grazie alla sua lunga esperienza nella costruzione degli anelli e all'ottimizzazione del progetto, Baruffaldi offre set di 3 anelli a dentatura frontale per qualsiasi impiego, progettati e costruiti secondo specifiche e disegni del cliente.

Caratteristiche principali:

- Set di 3 anelli a dentatura frontale, nessun sollevamento degli elementi indexati
- Alta precisione di posizionamento e di ripetibilità
- Numero di denti variabile a seconda delle esigenze di divisione del cliente
- Inclinazione del fianco del dente a 20°, che assicura elevata rigidità ed elevate capacità di carico
- Completamente personalizzati, possono sostituire qualsiasi sistema di indexaggio a 3 anelli impiegato in precedenza



Hirth couplings

Anelli Hirth

On many machine tools, such as vertical lathes and machining centers, it is necessary to provide an extremely stiff and strong system with very high position repeatability, in order to join RAM with different toolings.

Hirth rings are profitably used at this purpose, ensuring a very stiff, strong, precise and stable coupling.

While using them for many years in its own products, Baruffaldi has recently developed technical and production skills, in order to design and produce custom Hirth rings for market demand.

Main features

- High precision and positioning repeatability
- Different number of teeth in order to meet customer's division demands or fit to existing rings
- Full interchangeability with any other compatible Hirth ring on the market
- Fully customizable

Su molte macchine utensili, quali torni verticali e centri di lavoro, è necessario fornire un sistema di accoppiamento RAM-utensili che sia estremamente rigido, robusto e con alta precisione di ripetibilità.

A questo proposito vengono utilizzati con successo gli anelli Hirth, che assicurano un accoppiamento estremamente rigido, robusto, preciso e stabile nel tempo.

Baruffaldi utilizza tali anelli già da molto tempo per i propri prodotti e recentemente ha sviluppato competenze tecniche e di produzione idonee alla progettazione e produzione di anelli Hirth personalizzati per il mercato.

Caratteristiche principali:

- Elevata precisione di posizionamento e di ripetibilità
- Numero di denti variabile al fine di assecondare le necessità di divisione dei clienti o accoppiarsi ad anelli esistenti
- Completa intercambiabilità con qualsiasi anello Hirth compatibile esistente
- Pienamente personalizzabili





Hirth couplings - technical data

Corone Hirth - dati tecnici

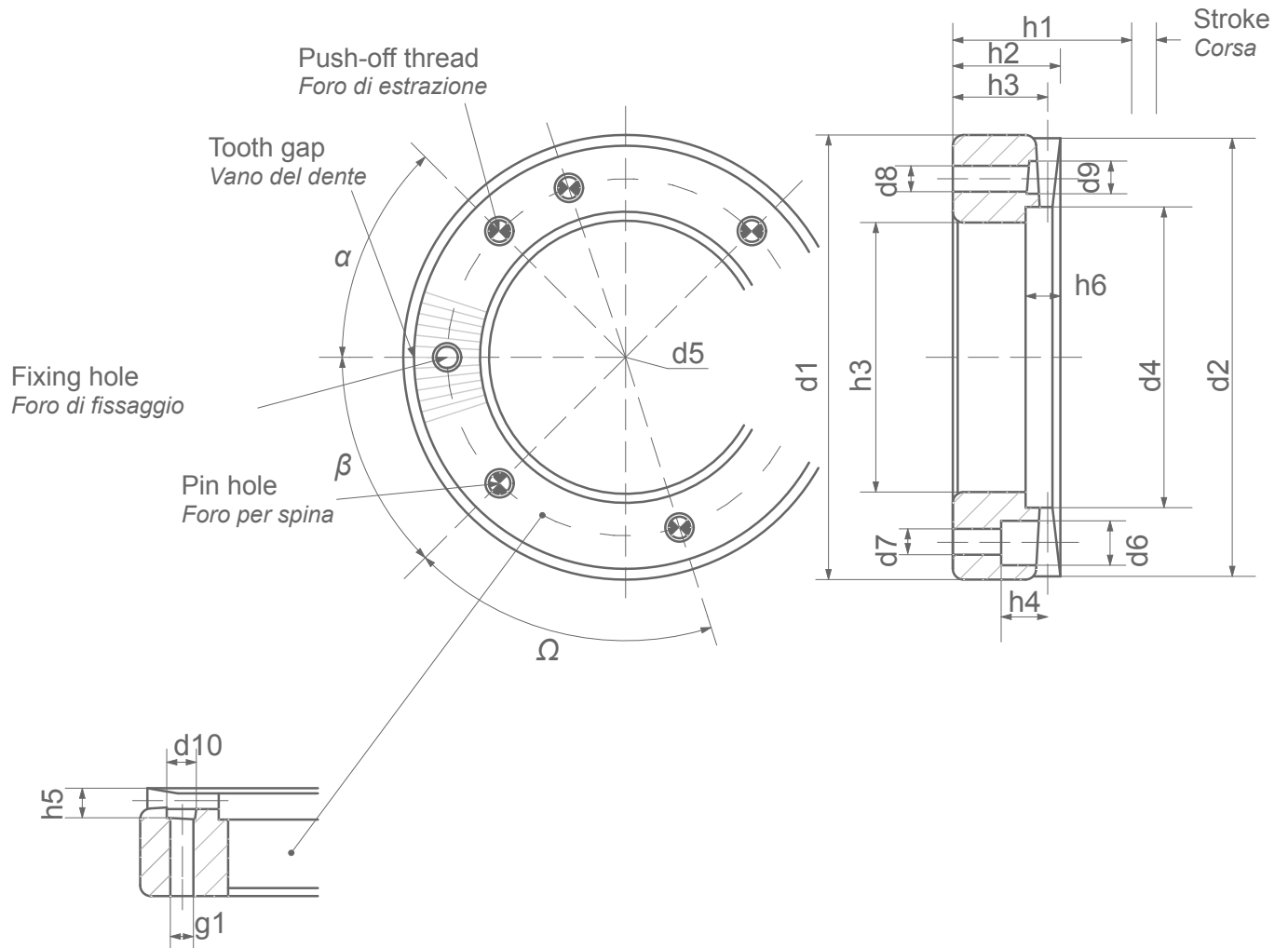
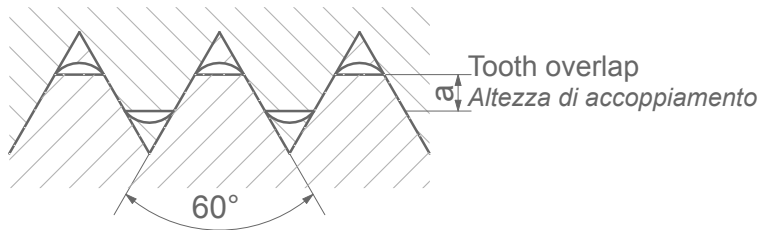



	Numero di denti Number of teeth	Corsa di sgancio Disengagement stroke	Altezza accoppiamento Tooth overlap	N° fori di fissaggio Fixing holes	N° fori per spina Pin holes	β	ρ	N° fori di estrazione Push-off thread	α	d2 \emptyset	d3 \emptyset h6	d4 \emptyset	d5 \emptyset $\pm 0,1$	d6 \emptyset	d7 \emptyset	d8 \emptyset	d9 \emptyset	d10 \emptyset	g1	h1 $\pm 0,1$	h2	h3 $\pm 0,1$	h4	h5	h6
$\emptyset 200$	60	4.7	4.5																		19.75				
	72	4.4	4.2																		19.6				
	96	3.4	3.2	6x60°	4	30°	72°	2x180°	30°	199	150	151	175	15	9	7	12	12	M8	35	19.1	17.5	14	6	5
	120	2.8	2.6																		18.8				
	144	2.3	2.1																		18.55				
$\emptyset 250$	60	5.4	5.2																		20.1				
	72	4.6	4.4																		19.7				
	96	3.9	3.7	10x36°	4	54°	72°	2x180°	18°	249	200	201	225	15	9	7	12	12	M8	35	19.4	17.5	13.5	5	5
	120	3.4	3.2																		19.1				
	144	2.8	2.6																		18.8				
	360	1.3	1.1																		18.1				
$\emptyset 280$	120	3.6	3.4																		21.7				
	144	3.1	2.9	10x36°	4	54°	72°	2x180°	18°	279	230	231	255	15	9	7	12	12	M8	40	21.45	20	14	6	5.5
	360	1.4	1.2																		20.6				
$\emptyset 320$	120	4.2	4																		22				
	144	3.6	3.4	10x36°	4	54°	72°	2x180°	18°	319	260	261	290	15	9	7	12	12	M8	40	21.7	20	14.5	6.5	5.5
	180	3	2.8																		21.4				
	360	1.6	1.4																		20.7				
$\emptyset 360$	120	4.6	4.4																		24.7				6
	144	3.9	3.7																		24.35				5
	180	3.3	3.1	10x36°	4	54°	72°	2x180°	18°	359	300	301	330	18	11	9	12	12	M8	45	24.05	22.5	15	6	5
	240	2.5	2.3																		23.65				5
	360	1.8	1.6																		23.3				5
$\emptyset 400$	120	4.7	4.5																		24.75				6
	144	4.5	4.3																		24.65				5
	180	3.6	3.4	10x36°	4	54°	72°	2x180°	18°	399	340	341	370	18	11	9	12	12	M8	45	24.2	22.5	15	6	5
	240	2.7	2.5																		23.75				5
	360	2	1.8																		23.4				5

In addition to the standard series, Baruffaldi can also provide customized rings
Please contact us for any details
+39 02 906090 - info.mtc@baruffaldi.it

Su richiesta, oltre alla serie standard, la baruffaldi è in grado di fornire anche corone personalizzate
Per informazioni contattaci
+39 20 906090 - info.mtc@baruffaldi.it

Worldwide sales and service organization

Organizzazione mondiale di vendite e servizi



Baruffaldi has developed a sales and service organisation all over the world. Furthermore, thanks to a net of agents and distributors, it is ensured a direct contact in many nations.

La Baruffaldi è strutturata per offrire un servizio di vendita e assistenza in tutto il mondo. Inoltre grazie ad una rete di agenti e distributori garantisce un contatto diretto in molte nazioni.



Italy



Spain



Germany



France



Bulgaria



Hungary



United Kindom



Republic of China



People's Republic of China



South Korea



United States of America



India

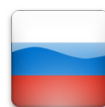

Russian Federation



Brazil

Baruffaldi

Machine tool components

Via Cristoforo Colombo, 4
20090 Settala (MI) - ITALY
Tel. +39 02 906090
Fax +39 02 906090015
sales.baruffaldi@baruffaldi.it

Registered Office

Via Cassino d'Alberi, 16
20067 Tribiano (MI) - ITALY
Tel. +39 02 906090
Fax +39 02 906090014



UCIMU-SISTEMI PER PRODURRE



www.baruffaldi.it