



BARUFFALDI
MACHINE TOOL COMPONENTS

High precision mechanical
industry development

since 1927



Catalogo dischi porta utensili
Tool holder disc catalogue



Codice per l'ordinazione dei dischi portautensili

Order code for Tool-holder disc

Tipo di disco portautensili <i>Type of tool holder disc</i>	code
Assiale VDI <i>Axial VDI</i>	PA
Con sedi fresate longitudinali <i>Longitudinal Milled seat</i>	PF
Assiale VDI doppio interasse <i>Axial Double PCD</i>	PD
Radiale VDI <i>Radial VDI</i>	PR
Radiale BMT <i>Radial BMT</i>	PB
Speciale <i>Special</i>	PS

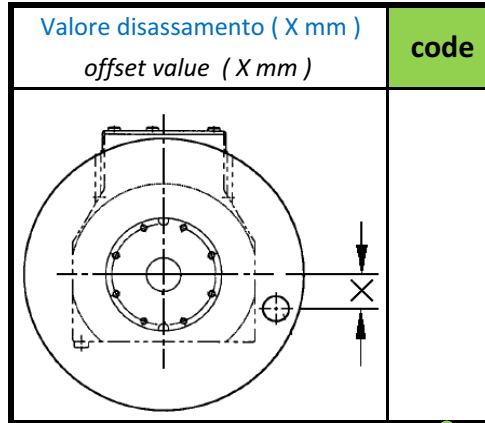

code	N° posizioni <i>N° of positions</i>
6	6
8	8
12	12
16	16

In base ai dati forniti dal cliente la Baruffaldi assegnerà il codice di riferimento del disegno

Based on the data provided by the customer Baruffaldi will assign the reference code of the drawing

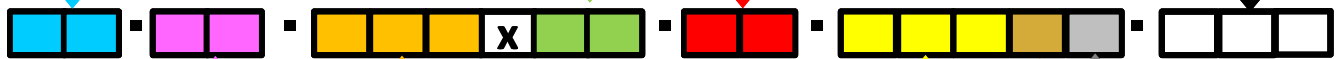

Larghezza cava o VDI \varnothing <i>VDI \varnothing or hole width</i>	code

Interasse fori (\varnothing) o chiave (Ch) <i>Distance between centers(\varnothing) or Key(Ch)</i>	code

Modello torretta <i>Turret type</i>	code
h mm	
80	80
50	100
63	120
80	160
100	200
125	250
160	320
200	400
260	500

Lato di lavoro <i>Working side</i>	code
	Destro <i>Right</i>
	D
	Sinistro <i>Left</i>
	S

Utilizzabile per torrette con utensili fissi e moduli rotanti <i>Suitable for turrets with static tools and driven tools</i>	code
	R
Utilizzabile solo per torrette con utensili fissi <i>Suitable only for turrets with static tools</i>	F



Disco con 8 sedi quadre reversibili e 8 sedi quadre portautensili longitudinali

Tool disc with 8 reversible square seats and 8 square seats for longitudinal toolholders

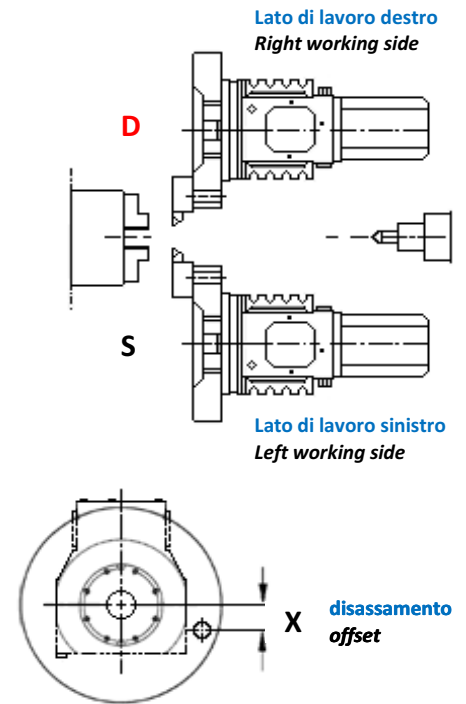
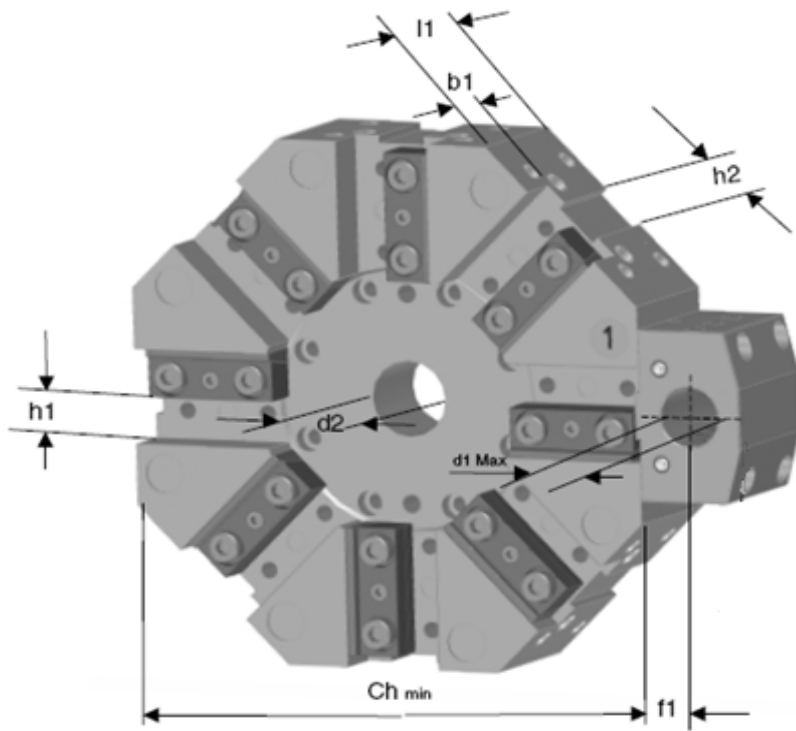

Codice N°	Dimensioni								Dimensions					
Code N°	h ₁	Ch	X	N° POS	Turret type	S D	F R	Disegno Drawing	d ₁	h ₂ m	d ₂	b ₁	Min l ₁	f ₁
	mm	mm	mm						mm	m	mm	mm	mm	mm
PF-12-150X00-08-100DF-A	12	150	00	08	100	D	F	A	20	12	25	12	41	20
PF-12-150X00-08-100SF-A	12	150	00	08	100	S	F	A	20	12	25	12	41	20
PF-16-190X00-08-120DF-A	16	190	00	08	120	D	F	A	25	16	30	16	51	23
PF-16-190X00-08-120SF-A	16	190	00	08	120	S	F	A	25	16	30	16	51	23
PF-20-220X00-08-120DF-A	20	220	00	08	120	D	F	A	32	20	30	20	61	25
PF-20-220X00-08-120SF-A	20	220	00	08	120	S	F	A	32	20	30	20	61	25
PF-25-275X00-08-160DF-A	25	275	00	08	160	D	F	A	40	25	40	25	76	30
PF-25-275X00-08-160SF-A	25	275	00	08	160	S	F	A	40	25	40	25	76	30
PF-32-350X00-08-200DF-A	32	350	00	08	200	D	F	A	50	32	50	32	96	35
PF-32-350X00-08-200SF-A	32	350	00	08	200	S	F	A	50	32	50	32	96	35
PF-40-450X00-08-250DF-A	40	450	00	08	250	D	F	A	60	40	63	40	126	40
PF-40-450X00-08-250SF-A	40	450	00	08	250	S	F	A	60	40	63	40	126	40

F Utilizzabile solo per torrette con utensili fissi
Suitable only for turrets with static tools

R Utilizzabile per torrette con utensili fissi e moduli rotanti
Suitable for turrets with static tools and driven tools



Disco con 12 sedi quadre reversibili e 12 sedi quadre portautensili longitudinali

Tooldisc with 12 reversible square seats and 12 square seats for longitudinal toolholders

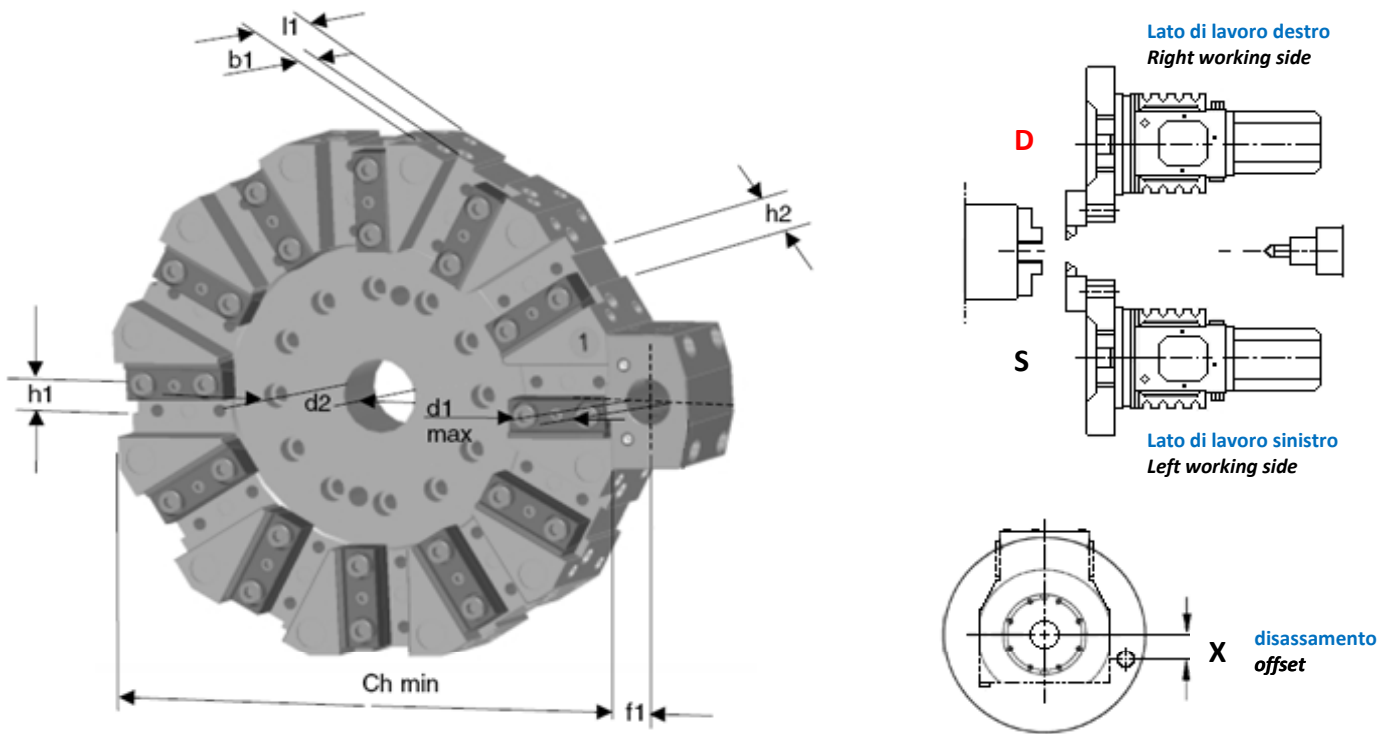

Codice N°	Dimensioni								Dimensions						
Code N°	h ₁	Ch	X	N° POS	Turret type	S D	F R	Disegno Drawing	d ₁	h _{2m}	d ₂	b ₁	l ₁	f ₁	Min
	mm	mm	mm						mm	m	mm	mm	mm	mm	mm
PF-12-175X00-12-100DF-A	12	175	00	12	100	D	F	A	20	12	25	12	41	20	
PF-12-175X00-12-100SF-A	12	175	00	12	100	S	F	A	20	12	25	12	41	20	
PF-16-230X00-12-120DF-A	16	230	00	12	120	D	F	A	25	16	30	16	51	23	
PF-16-230X00-12-120SF-A	16	230	00	12	120	S	F	A	25	16	30	16	51	23	
PF-20-278X00-12-160DF-A	20	278	00	12	160	D	F	A	32	20	40	20	61	25	
PF-20-278X00-12-160SF-A	20	278	00	12	160	S	F	A	32	20	40	20	61	25	
PF-25-345X00-12-200DF-A	25	345	00	12	200	D	F	A	40	25	50	25	76	30	
PF-25-345X00-12-200SF-A	25	345	00	12	200	S	F	A	40	25	50	25	76	30	
PF-32-435X00-12-250DF-A	32	435	00	12	250	D	F	A	50	32	63	32	96	35	
PF-32-435X00-12-250SF-A	32	435	00	12	250	S	F	A	50	32	63	32	96	35	
PF-40-565X00-12-320DF-A	40	565	00	12	320	D	F	A	60	40	80	40	126	40	
PF-40-565X00-12-320SF-A	40	565	00	12	320	S	F	A	60	40	80	40	126	40	

F Utilizzabile solo per torrette con utensili fissi
Suitable only for turrets with static tools

R Utilizzabile per torrette con utensili fissi e moduli rotanti
Suitable for turrets with static tools and driven tools



Disco per 6 portautensili secondo norme DIN 69880

Tool disc for 6 VDI toolholders as per DIN norms 69880

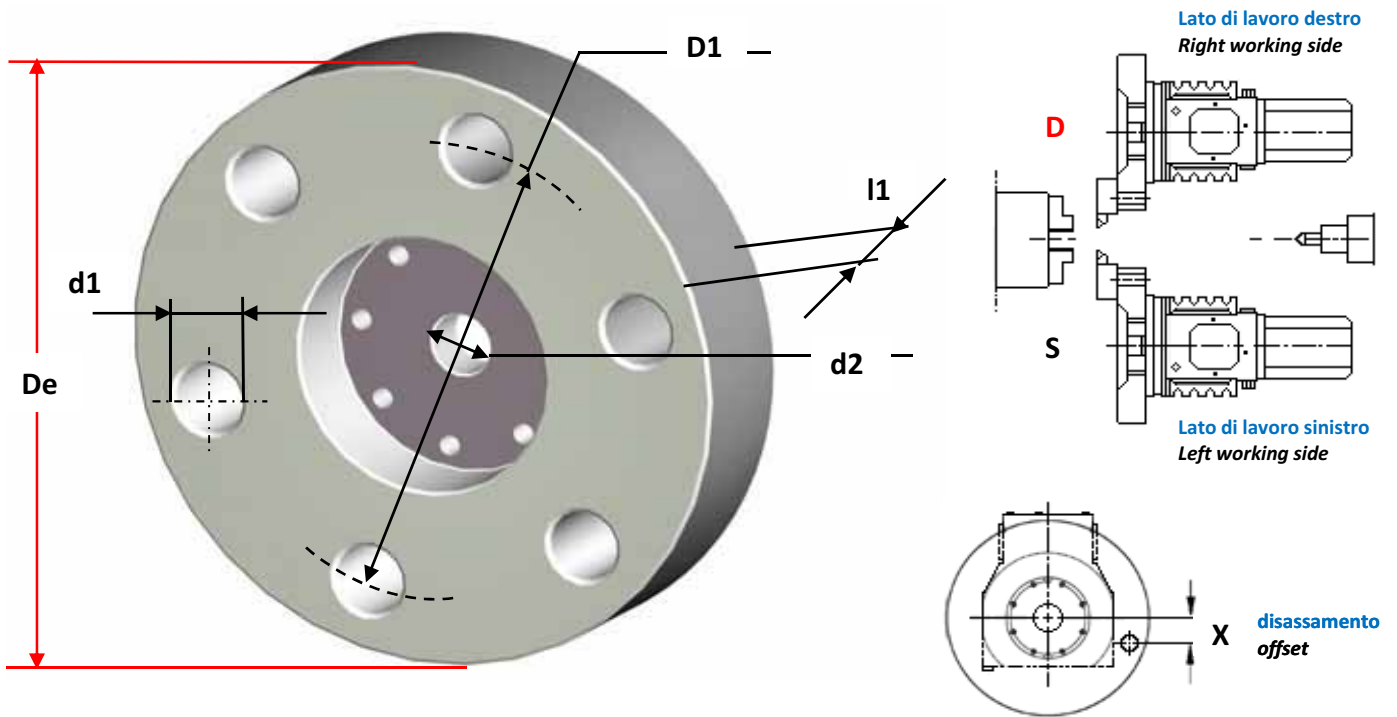

Codice N°	Dimensioni								Dimensions				
Code N°	VDI	PCD	N°	Turret	S	F	Disegno	PCD	Min				
	d ₁	D ₁	X	POS	type	D	R	Drawing	D ₂	De	d ₂	l ₁	D ₃
	mm	mm	mm						mm	mm	mm	mm	mm
PA-40-270X00-06-120DF-024	40	270	00	06	120	D	F	024		340	30	65	
PA-30-200X00-06-120DF-033	30	200	00	06	120	D	F	033		260	30	57	
PA-30-200X00-06-120SF-034	30	200	00	06	120	S	F	034		260	30	57	
PA-40-230X00-06-120DF-040	40	230	00	06	120	D	F	040		290	65		
PA-40-270X35-06-160DR-039	40	270	35	06	160	D	R	069		335	40	77,7	
PA-40-272X00-06-200DF-084	40	272	00	06	200	D	F	084		332	50	78	
PA-50-300X00-06-200SF-095	50	300	00	06	200	S	F	095		375	50	82	
PA-40-340X00-06-200SR-109	40	340	00	06	200	S	R	109		410	50	66	
PA-40-340X32-06-200SF-120	40	340	32	06	200	S	F	120		410	50	66	

F Utilizzabile solo per torrette con utensili fissi
 Suitable only for turrets with static tools

R Utilizzabile per torrette con utensili fissi e moduli rotanti
 Suitable for turrets with static tools and driven tools



Disco per 8 portautensili secondo norme DIN 69880

Tooldisc for 8 VDI toolholders as per DIN norms 69880

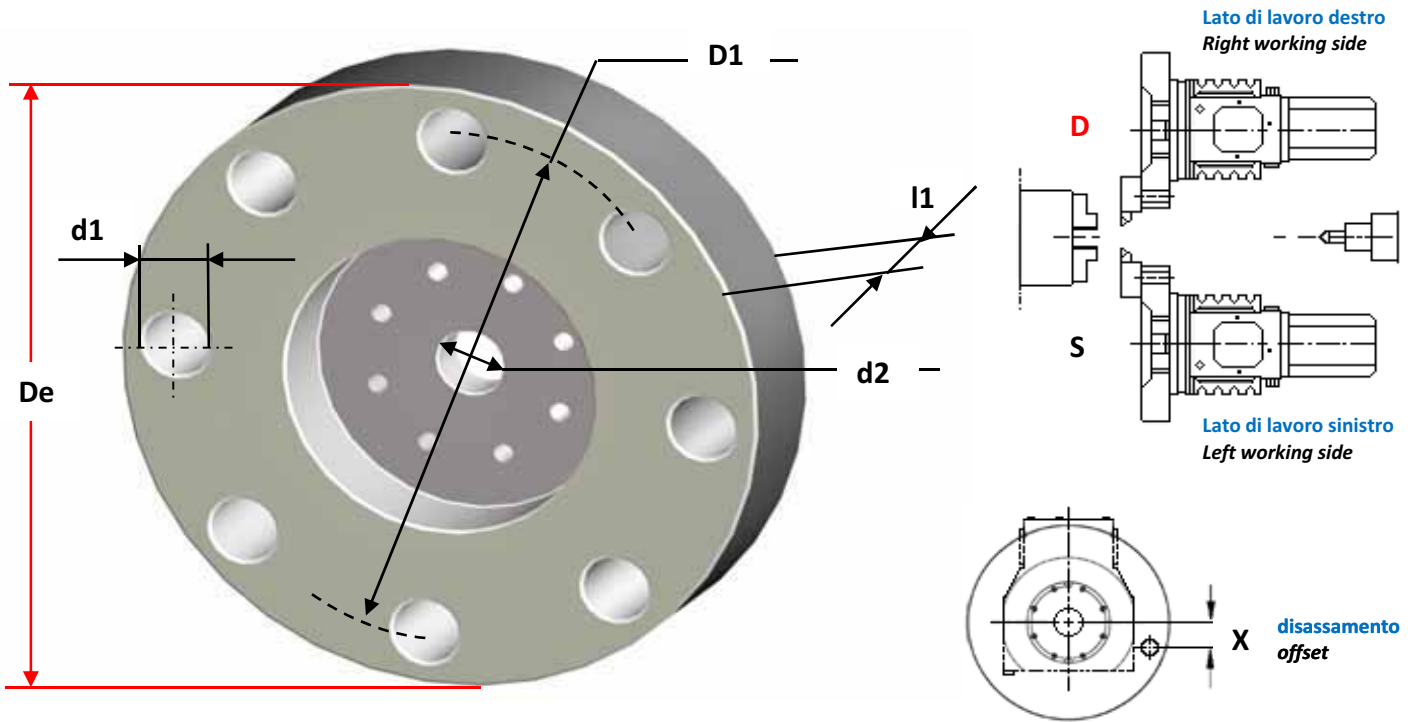

Codice N°	Dimensioni								Dimensions				
Code N°	VDI d ₁ mm	PCD D ₁ mm	X mm	N° POS	Turret type	S D	F R	Disegno Drawing	PCD D ₂ mm	De mm	d ₂ mm	l ₁ mm	Min D ₃ mm
PA-20-225X00-08-120DR-006	20	225	00	08	120	D	R	006		275	30	44	
PA-25-225X00-08-120DR-008	25	225	00	08	120	D	R	008		275	30	52	
PA-30-240X00-08-120DF-011	30	240	00	08	120	D	F	011		290	30	59	
PA-30-240X00-08-120SF-016	30	240	00	08	120	S	F	016		290	30	59	
PA-30-205X00-08-120SF-018	30	205	00	08	120	S	F	018		255	30	59	
PA-30-190X00-08-120DF-019	30	190	00	08	120	D	F	019		240	30	57	
PA-30-225X00-08-120SR-023	30	225	00	08	120	S	R	023		275	30	71	
PA-30-200X00-08-120DF-025	30	200	00	08	120	D	F	025		260	30	58	
PA-30-240X00-08-120SR-027	30	240	00	08	120	S	R	027		290	30	71	
PA-30-240X00-08-120DR-028	30	240	00	08	120	D	R	028		290	30	71	
PA-30-240X15-08-120DF-031	30	240	15	08	120	D	F	031		290	30	59	
PA-30-225X17-08-120DR-036	30	225	17	08	120	D	R	036		275	30	71	
PA-30-225X00-08-120DR-037	30	225	00	08	120	D	R	037		275	30	71	

F Utilizzabile solo per torrette con utensili fissi
 Suitable only for turrets with static tools

R Utilizzabile per torrette con utensili fissi e moduli rotanti
 Suitable for turrets with static tools and driven tools



Disco per 8 portautensili secondo norme DIN 69880

Tooldisc for 8 VDI toolholders as per DIN norms 69880

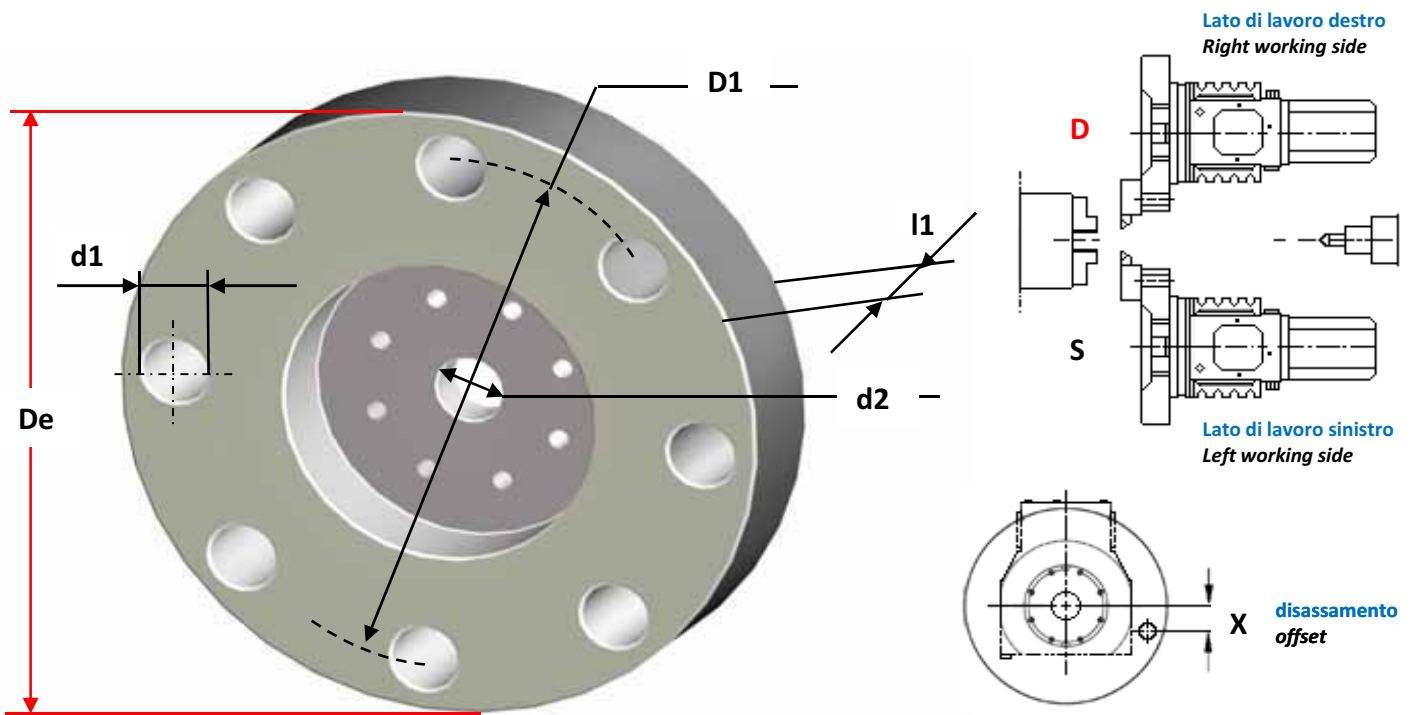

Codice N°	Dimensioni								Dimensions				
Code N°	VDI d ₁ mm	PCD D ₁ mm	X mm	N° POS	Turret type	S D	F R	Disegno Drawing	PCD D ₂ mm	De mm	d ₂ mm	l ₁ mm	Min D ₃ mm
PA-30-270X00-08-160DR-039	30	270	00	08	160	D	R	039		322	40	58	
PA-30-270X25-08-160DR-040	30	270	25	08	160	D	R	040		322	40	58	
PA-40-270X25-08-160SR-043	40	270	25	08	160	S	R	043		340	40	77,7	
PA-40-270X00-08-160SR-044	40	270	00	08	160	S	R	044		340	40	77,7	
PA-30-270X00-08-160SR-045	30	270	00	08	160	S	R	045		322	40	58	
PA-40-270X00-08-160SF-047	40	270	00	08	160	S	F	047		340	40	65	
PA-40-270X00-08-160DR-051	40	270	00	08	160	D	R	051		335	40	77,7	
PA-40-245X00-08-160DF-052	40	245	00	08	160	D	F	052		305	40	77,7	
PA-30-190X00-08-160DF-055	30	190	00	08	160	D	F	055		240	40	68	
PA-30-190X00-08-160SF-056	30	190	00	08	160	S	F	056		240	40	68	
PA-40-245X25-08-160DF-057	40	245	25	08	160	D	F	057		305	40	65	
PA-40-245X00-08-160SF-058	40	245	00	08	160	S	F	058		315	40	65	
PA-30-270X35-08-160DR-063	30	270	35	08	160	D	R	063		322	40	58	
PA-30-210X00-08-160DF-064	30	210	00	08	160	D	F	064		260	40	68	
PA-50-290X00-08-160DF-067	50	290	00	08	160	D	F	067		363	40	80	
PA-40-270X25-08-160DR-070	40	270	25	08	160	D	R	070		335	40	77,7	
PA-40-350X00-08-160DF-075	40	350	00	08	160	D	F	075		405	40	66	
PA-40-350X40-08-160SF-076	40	350	40	08	160	S	F	076		380	40	66	

F Utilizzabile solo per torrette con utensili fissi
 Suitable only for turrets with static tools

R Utilizzabile per torrette con utensili fissi e moduli rotanti
 Suitable for turrets with static tools and driven tools



Disco per 8 portautensili secondo norme DIN 69880

Tooldisc for 8 VDI toolholders as per DIN norms 69880

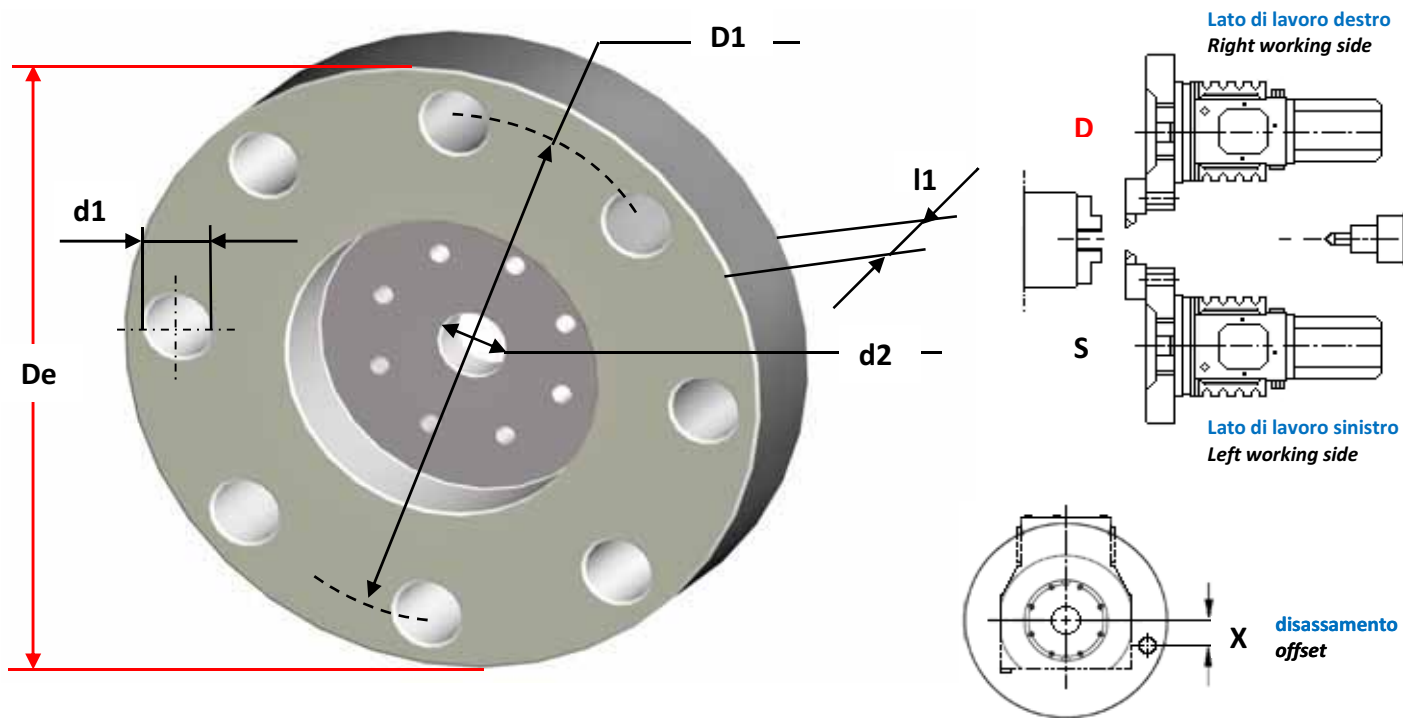

Codice N°	Dimensioni								Dimensions						
Code N°	VDI	PCD	N° POS	Turret type	S	F	Disegno Drawing	PCD	Min						
	d ₁	D ₁								X	D ₂	De	d ₂	l ₁	D ₃
	mm	mm	mm					mm	mm	mm	mm	mm	mm	mm	mm
PA-50-340X00-08-200SR-064	50	340	00	08	200	S	R	064		420	50	82			
PA-40-340X00-08-200SR-066	40	340	00	08	200	S	R	066		410	50	66			
PA-40-340X32-08-200SR-068	40	340	32	08	200	S	R	068		410	50	66			
PA-40-340X00-08-200DF-073	40	340	00	08	200	D	F	073		410	50	66			
PA-40-272X00-08-200SF-074	40	272	00	08	200	S	F	074		340	50	70			
PA-50-340X00-08-200DR-077	50	340	00	08	200	D	R	077		420	50	82			
PA-50-340X32-08-200SR-078	50	340	32	08	200	S	R	078		420	50	82			
PA-50-272X35-08-200SF-079	50	272	35	08	200	S	F	079		355	50	80			
PA-50-290X00-08-200DF-080	50	290	00	08	200	D	F	080		365	50	80			
PA-40-245X00-08-200SF-081	40	245	00	08	200	S	F	081		305	50	78			
PA-40-310X00-08-200DS-086	40	310	00	08	200	D		086		380	50	66			
PA-50-290X35-08-200SF-088	50	290	35	08	200	S	F	088		375	50	82			
PA-50-340X00-08-200DR-094	50	340	00	08	200	D	R	094		420	50	82			
PA-40-170X32-08-200DR-108	40	340	32	08	200	D	R	108		410	50	82			
PA-50-170X32-08-200DF-116	50	340	32	08	200	D	F	116		410	50	80			
PA-40-290X00-08-200DF-119	40	290	00	08	200	D	F	119		360	50	66			
PA-40-272X32-08-200SF-122	40	272	32	08	200	S	F	122		340	50				

F Utilizzabile solo per torrette con utensili fissi
 Suitable only for turrets with static tools

R Utilizzabile per torrette con utensili fissi e moduli rotanti
 Suitable for turrets with static tools and driven tools



Disco per 8 portautensili secondo norme DIN 69880

Tool disc for 8 VDI toolholders as per DIN norms 69880

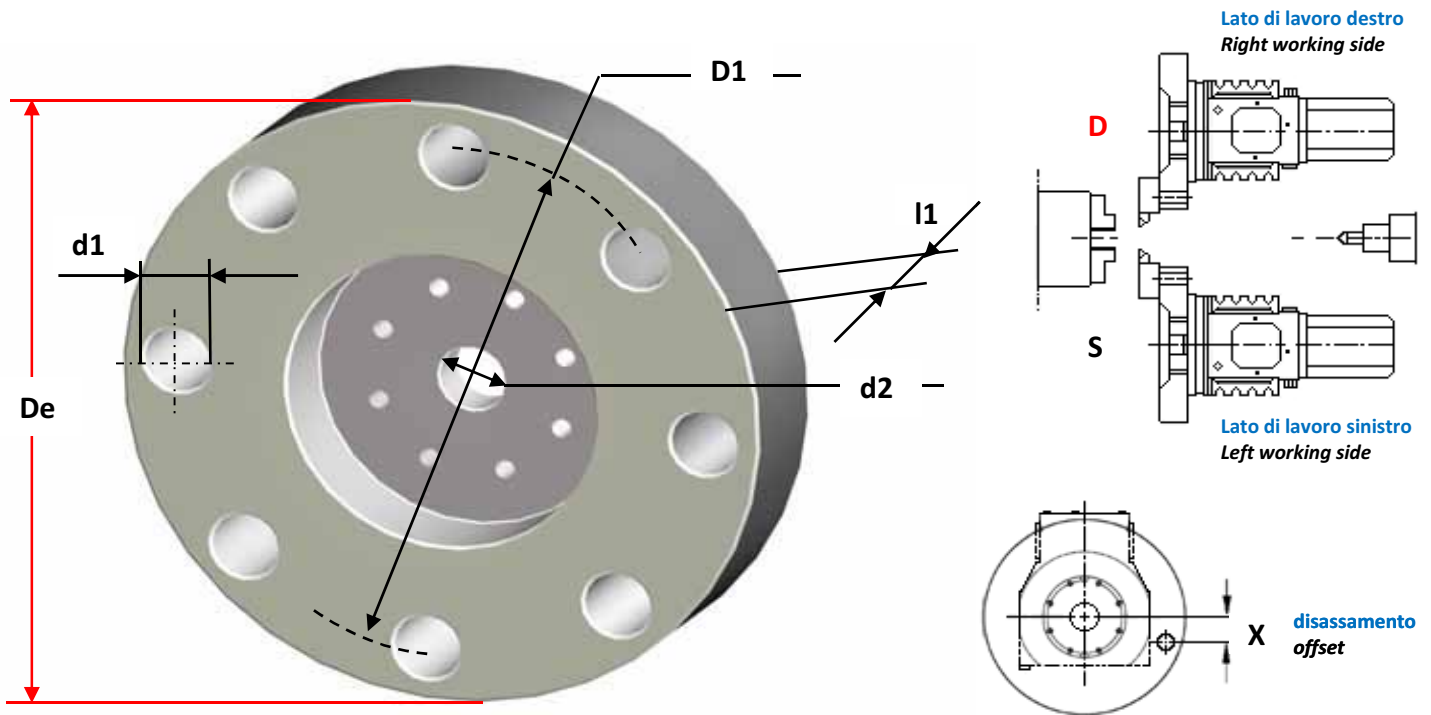

Codice N°	Dimensioni								Dimensions				
Code N°	VDI d ₁ mm	PCD D ₁ mm	X mm	N° POS	Turret type	S D	F R	Disegno Drawing	PCD D ₂ mm	De mm	d ₂ mm	l ₁ mm	Min D ₃ mm
PA-50-400X00-08-250SR-015	50	400	00	08	250	S	R	015		473	63	82	
PA-50-340X35-08-250SF-029	50	340	35	08	250	S	F	029		420	63	82	
PA-50-290X00-08-250DF-048	50	290	00	08	250	D	F	048		365	63	95	
PA-60-400X00-08-250SR-056	60	400	00	08	250	S	R	056		490	63	115	
PA-50-400X00-08-250DR-079	50	400	00	8	250	D	R	079		473	63	82	
PA-60-490X00-08-320SR-038	60	490	00	08	320	S	R	038		582	80	100	
PA-60-490X00-08-320DR-040	60	490	00	08	320	D	R	040		582	80	100	
PA-80-550X00-08-400SF-023	80	550	00	08	400	S	F	023		670		130	
PA-80-620X00-08-400SR-027	80	620	00	08	400	S	R	027		740		130	
PA-80-620X00-08-400SF-029	80	620	00	08	400	S	F	029		740		150	

F Utilizzabile solo per torrette con utensili fissi
 Suitable only for turrets with static tools

R Utilizzabile per torrette con utensili fissi e moduli rotanti
 Suitable for turrets with static tools and driven tools



Disco per 12 portautensili secondo norme DIN 69880

Tooldisc for 12 VDI toolholders as per DIN norms 69880

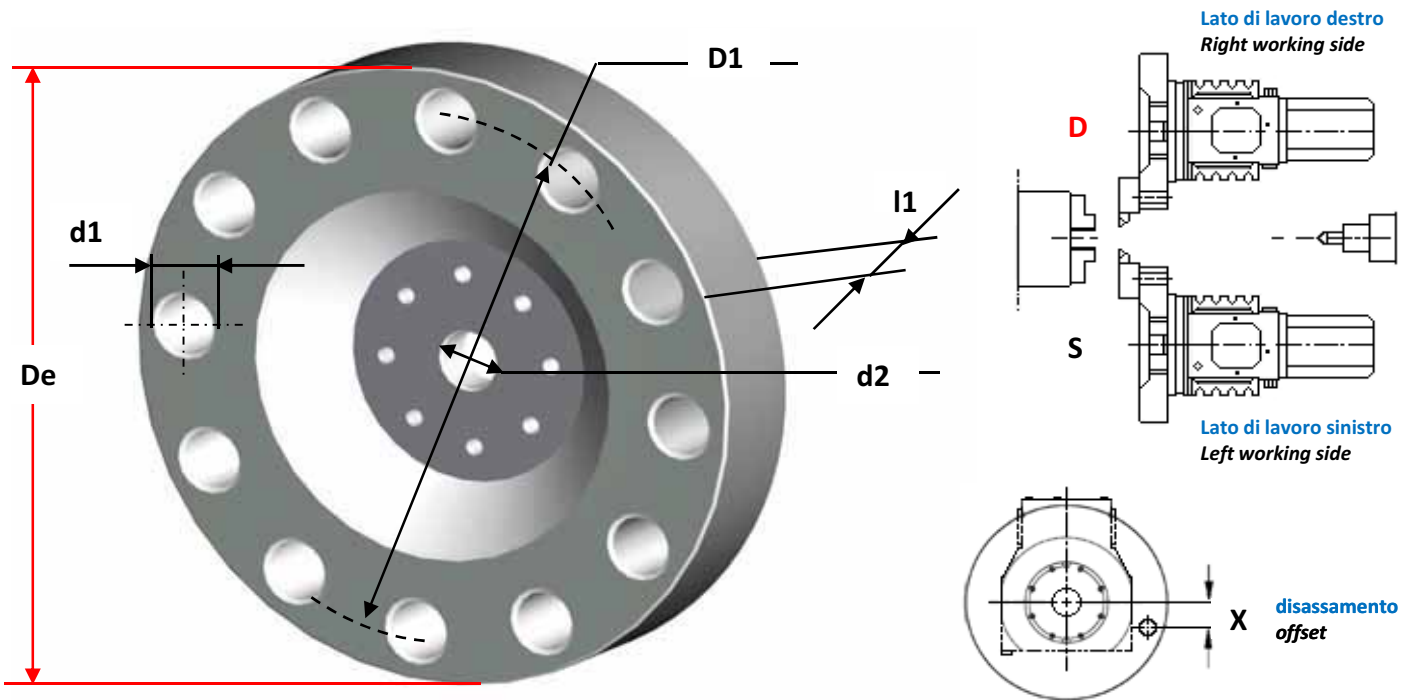

Codice N°	Dimensioni								Dimensions				
Code N°	VDI d ₁ mm	PCD D ₁ mm	X mm	N° POS	Turret type	S D	F R	Disegno Drawing	PCD D ₂ mm	De mm	d ₂ mm	l ₁ mm	Min D ₃ mm
PA-16-190X15-12-100DR-001	16	190	15	12	100	D	R	001		230	25	48	
PA-20-225X00-12-120DR-007	20	225	00	12	120	D	R	007		275	30	44	
PA-25-225X00-12-120DR-009	25	225	00	12	120	D	R	009		275	30	52	
PA-30-290X00-12-120DF-013	30	290	00	12	120	D	F	013		345	30	58	
PA-20-240X00-12-120DR-015	20	240	00	12	120	D	R	015		290	30	44	
PA-20-225X17-12-120DR-026	20	225	17	12	120	D	R	026		275	30	44	
PA-30-270X00-12-120DF-029	30	270	00	12	120	D	F	029		322	30	56	
PA-30-270X00-12-120DR-035	30	270	00	12	120	D	R	035		322	30	67	DIN 5480
PA-30-270X25-12-160DR-019	30	270	25	12	160	D	R	019		322	40	58	
PA-30-270X00-12-160DR-026	30	270	00	12	160	D	R	026		322	40	58	
PA-30-300X00-12-160DR-038	30	300	00	12	160	D	R	038		352	40	58	
PA-20-270X25-12-160DR-049	20	270	25	12	160	D	R	049		322	40	43	
PA-30-270X35-12-160DR-061	30	270	35	12	160	D	R	061		322	40	58	
PA-30-270X00-12-160SR-066	30	270	00	12	160	S	R	061		322	40	58	
PA-30-340X00-12-160DF-077	30	340	0	12	160	D	F	077		392	40	56	

F Utilizzabile solo per torrette con utensili fissi
 Suitable only for turrets with static tools

R Utilizzabile per torrette con utensili fissi e moduli rotanti
 Suitable for turrets with static tools and driven tools



Disco per 12 portautensili secondo norme DIN 69880

Tooldisc for 12 VDI toolholders as per DIN norms 69880

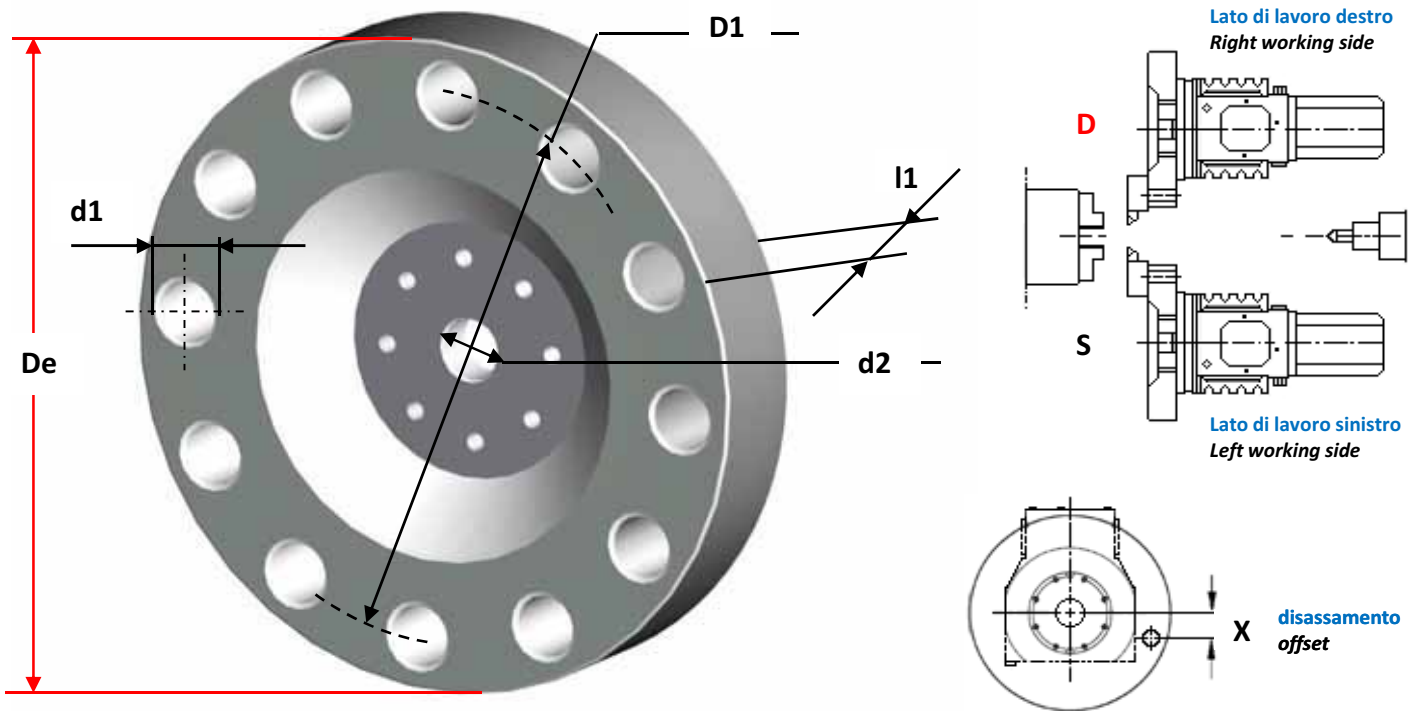

Codice N°	Dimensioni								Dimensions				
Code N°	VDI d ₁ mm	PCD D ₁ mm	X mm	N° POS	Turret type	S D	F R	Disegno Drawing	PCD D ₂ mm	De mm	d ₂ mm	l ₁ mm	Min D ₃ mm
PA-40-340X00-12-200DR-042	40	340	00	12	200	D	R	042		410	50	66	
PA-40-340X32-12-200DR-046	40	340	32	12	200	D	R	046		410	50	66	
PA-40-446X80-12-200DR-047	40	380	80	12	200	D	R	047		450	50	66	
PA-40-340X00-12-200SR-060	40	340	00	12	200	S	R	060		410	50	66	
PA-40-340X32-12-200SR-076	40	340	32	12	200	S	R	076		410	50	66	
PA-40-340X40-12-200DR-083	40	340	40	12	200	D	R	083		410	50	66	
PA-40-380X00-12-200DR-089	40	380	00	12	200	D	R	089		450	50	66	
PA-30-340X00-12-200DR-092	30	340	00	12	200	D	R	092		410	50	58	
PA-50-400X00-12-250DR-011	50	400	00	12	250	D	R	011		473	63	82	
PA-50-400X35-12-250DR-013	50	400	35	12	250	D	R	013		473	63	82	
PA-50-400X00-12-250SR-028	50	400	00	12	250	S	R	028		473	63	82	
PA-50-400X45-12-250DF-041	50	400	45	12	250	D	F	041		473	63	100	
PA-50-400X35-12-250SR-043	50	400	35	12	250	S	R	043		473	63	82	
PA-40-400X00-12-250DR-019	40	400	00	12	250	D	R	019		473	63	66	
PA-50-400X50-12-250DR-060	50	400	50	12	250	D	R	060		473	63	82	
PA-40-345X00-12-250DR-062	40	345	00	12	250	D	F	062		405	63	66	
PA-50-400X00-20-250DR-063	50	400	20	12	250	D	F	063		473	63	82	

F Utilizzabile solo per torrette con utensili fissi
Suitable only for turrets with static tools

R Utilizzabile per torrette con utensili fissi e moduli rotanti
Suitable for turrets with static tools and driven tools



Disco per 12 portautensili secondo norme DIN 69880

Tooldisc for 12 VDI toolholders as per DIN norms 69880

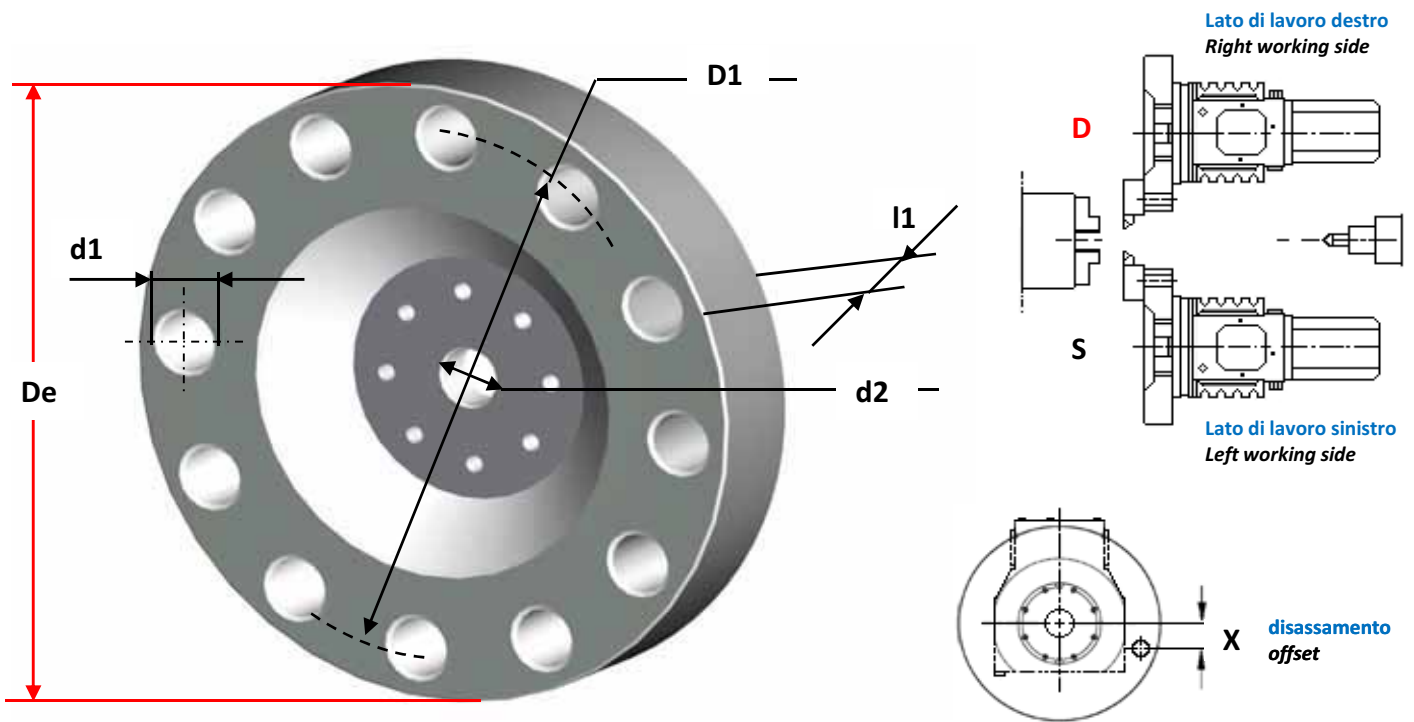

Codice N°	Dimensioni								Dimensions				
Code N°	VDI	PCD		N°	Turret	S	F	Disegno	PCD			Min	
	d ₁	D ₁	X	POS	type	D	R	Drawing	D ₂	De	d ₂	l ₁	D ₃
	mm	mm	mm						mm	mm	mm	mm	mm
PA-60-476X00-12-320DF-027	60	476	00	12	320	D	F	027		570	80	95	
PA-60-490X00-12-320DR-030	60	490	00	12	320	D	R	030		582	80	100	
PA-60-490X00-12-320SR-035	60	490	00	12	320	S	R	035		582	80	100	
PA-60-490X55-12-320DR-036	60	490	55	12	320	D	R	036		582	80	100	
PA-60-530X00-12-400DF-018	60	530	00	12	400	D	F	018		630	100	95	
PA-80-620X00-12-400DR-022	80	620	00	12	400	D	R	022		740	100	130	
PA-80-620X00-12-400SR-028	80	620	00	12	400	S	R	028		740	100	130	

F Utilizzabile solo per torrette con utensili fissi
Suitable only for turrets with static tools

R Utilizzabile per torrette con utensili fissi e moduli rotanti
Suitable for turrets with static tools and driven tools



Disco per 12 portautensili secondo norme DIN 69880

Doppio interasse

Tooldisc for 12 VDI toolholders as per DIN norms 69880

Double PCD

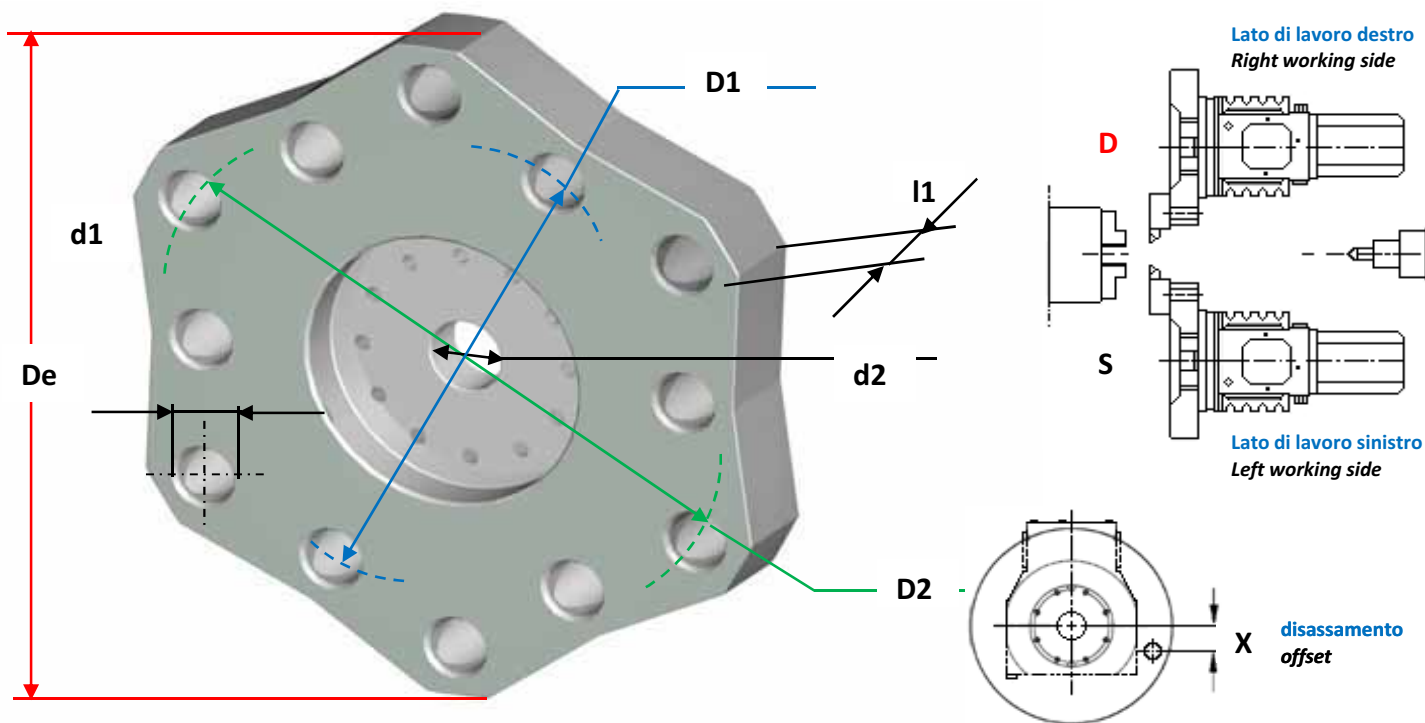

Codice N°	Dimensioni								Dimensions					
Code N°	VDI	PCD	N° POS	Turret type	S	F	Disegno Drawing	PCD	Min					
	d ₁	D ₁								X	D ₂	De	d ₂	l ₁
	mm	mm	mm					mm	mm	mm	mm	mm		
PD-20-200X00-12-120DF-041	20	200	00	12	120	D	F	041	240	275	30	42		
PD-30-270X00-12-160DR-037	30	270	00	12	160	D	R	037	335	390	40	58		
PD-30-265X22-12-160DF-046	30	265	22	12	160	D	F	046	330	400	40	56		
PD-30-265X25-12-160DF-048	30	265	25	12	160	D	F	048	330	390	40	58		
PD-40-340X00-12-200DR-053	40	340	00	12	200	D	R	053	400	470	50	66		
PD-40-310X25-12-200DF-087	40	310	25	12	200	D	F	087	360	446	50	65		
PD-40-340X32-12-200DF-115	40	340	32	12	200	D	F	115	400	470	50	66		
PD-50-400X00-12-250DR-026	50	400	00	12	250	D	R	026	460	540	63	82		
PD-40-400X00-12-250DR-027	40	400	00	12	250	D	R	027	460	540	63	66		
PD-40-380X80-12-250DF-064	40	380	80	12	250	D	F	064	450	520	63	65		
PD-50-400X00-12-250DR-083	50	400	00	12	250	D	R	083	510	590	63	82		
PD-60-400X00-12-320DR-034	60	490	00	12	320	D	R	034	570	662	80			
PD-60-620X00-12-400DR-030	60	620	00	12	400	D	R	030	830	920				

F Utilizzabile solo per torrette con utensili fissi

F

Suitable only for turrets with static tools

R Utilizzabile per torrette con utensili fissi e moduli rotanti

R

Suitable for turrets with static tools and driven tools



Disco portautensili assiale speciale

Special axial Tooldisc

Su richiesta sono inoltre disponibili torrette e dischi per applicazioni speciali.

Esempio dischi portautensili con modulo di rettifica.

Non esitate a contattare l'ufficio vendite.

Furthermore, on demand, are available turrets and discs with special applications.

Example, tool disc with grinding unit.

Do not hesitate to contact the sales office.

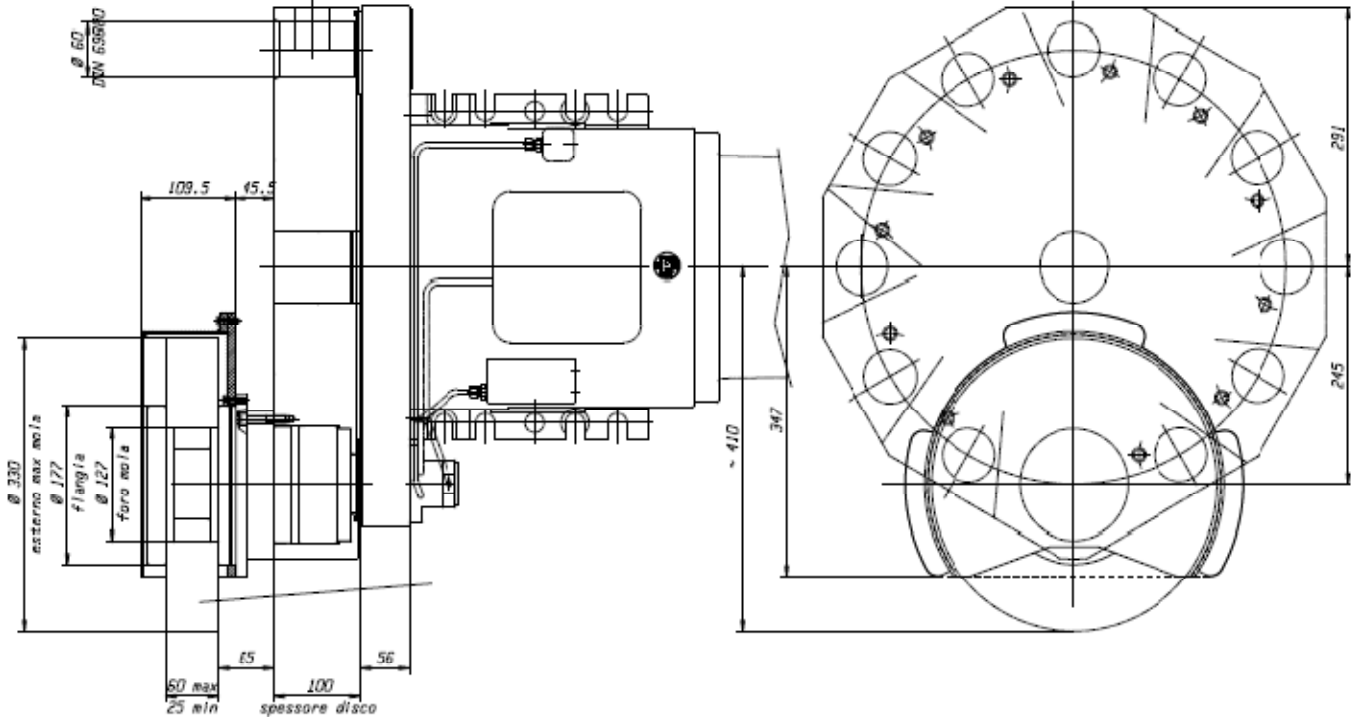

Codice N°	Dimensioni								Dimensions				
Code N°	VDI	PCD		N°	Turret	S	F	Disegno	PCD	Min			
	d ₁	D ₁	X	POS	type	D	R	Drawing	D ₂	D _e	d ₂	l ₁	D ₃
	mm	mm	mm						mm	mm	mm	mm	mm
	disco portautensili con modulo di rettifica								tool disc with grinding unit				
PS-60-490X00-12-320DR-032	60	490	00	12	320	D	R	032		582	80	100	
PS-60-490X00-12-320SR-033	60	490	00	12	320	S	R	033		582	80	100	
PS-80-620X00-12-400DR-024	80	620	00	12	400	D	R	024		740	100	130	
PS-80-620X00-12-400SR-025	80	620	00	12	400	S	R	025		740	100	130	

Baruffaldi inoltre offre una serie di accessori (moduli rotanti e portautensili) che permette l'acquisto di pacchetti completi, garantiti ed economici.

Baruffaldi offers a series of accessories (driven tools and toolholders), which facilitate the purchase of complete, warranted and economic full package.





Organizzazione mondiale di vendite e servizi *Worldwide sales and service organization*

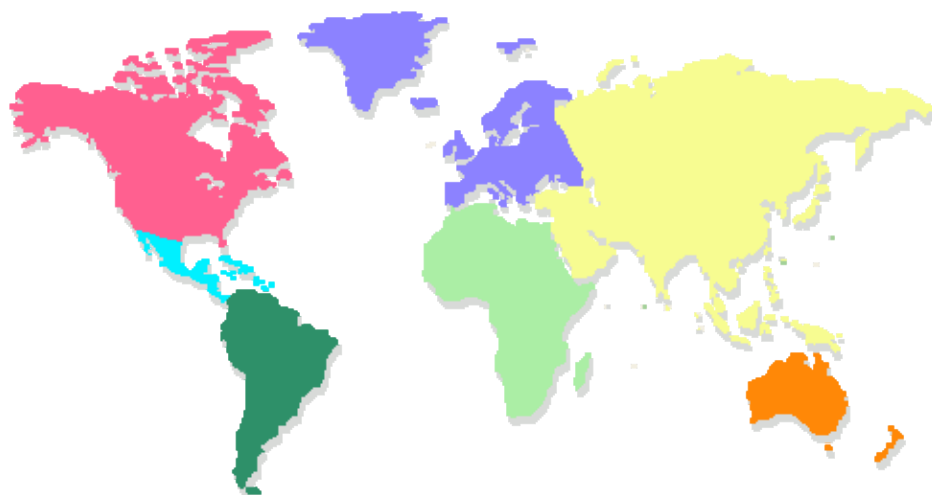

La Baruffaldi è strutturata per offrire un servizio di vendita e assistenza in tutto il mondo. Inoltre grazie ad una rete di agenti e distributori garantisce un contatto diretto in molte nazioni. Per ulteriori informazioni, contattare i nostri uffici.
sales.baruffaldi@baruffaldi.it
www.baruffaldi.it
Tel. +39 02 906090 Fax +39 02 906090 14

Baruffaldi is structured to offer a service of sale and service in all the world. Furthermore thanks to a net of agents and distributors we ensures a direct contact in many nations. For further the information, contact our offices.
sales.baruffaldi@baruffaldi.it
www.baruffaldi.it
Tel. +39 02 906090 Fax +39 02 906090 14



Italy



Spain



Germany



France



Bulgaria



Hungary



United Kindom



Europe



Republic of China Taiwan (ROC)



People's Republic of China (PRC)



South Korea



United States of America



India

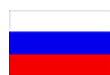

Russian Federation



BARUFFALDI
MACHINE TOOL COMPONENTS



Via Cristoforo Colombo, 4
20090 Settala (MI) - Italy
Tel. +39 02 906090
Fax +39 02 90609015
sales.baruffaldi@baruffaldi.it
www. Baruffaldi. It

Sede legale Registered Office
Via Cassino d'Alberi, 16
20067 Tribiano (MI) - Italy
Tel. +39 02 906090
Fax +39 02 90609014

- Ci riserviamo di modificare in qualsiasi momento, senza preavviso, le caratteristiche tecniche, le dimensioni ed i pesi indicati nel presente catalogo. Le illustrazioni non sono impegnative.
- *The technical data, dimensions and weights are subject to change unless otherwise stated in the individual pages of this catalogue. The illustrations are for reference only.*